



Carbon Dioxide Gas Detector Operating Manual

We are an Australian, made
and Owned manufacturer



© Copyright Gas Detection (Australia) Pty Ltd 2024

Contents

1 Proprietary	4
1.1 Statement	4
1.2 Disclaimer	4
2 Warnings, Cautions and Notes	4
3 Introduction	5
3.1 Purpose And Contents of Manual	5
3.2 Product Identification	5
3.2.1 Contents of Package	5
3.2.2 Enclosure	5
3.3 Product Description	6
3.3.1 Purpose of Product	6
3.3.2 Description of Operation	6
4 Installation	7
4.1 Installation Recommendations	7
4.2 Mounting the Enclosures	7
4.2.1 Dimensions	7
4.3 Electrical Connections	9
4.3.1 Installation Cable Choice	9
4.3.2 Cable Shield	10
4.3.3 Cable Gland	10
4.3.4 0-10 V Output	10
5 Functions	11
5.1 Status LED	11
5.2 Menu/Mute Button	11
5.3 Configuration Jumpers	13
5.3.1 Mute	13
5.3.2 Fault State mA Output	13
5.4 mA Test Points	13
5.5 Alarm Level Relay Setting	14
6 Verification of Installation	15
7 Commissioning	16
7.1 Initial Commissioning	16
7.2 Function Checks	17
7.2.1 Equipment required for Function Checks	17
7.2.2 Bump Test Conditions	17
7.2.3 Bump Test Procedure	17
7.2.4 Failure of Bump Test	17
7.2.5 Fault Condition	17
8 Calibration Procedure	18
8.1 The Purpose of Calibration	18
8.1.1 Preparing for Calibration	18
8.2 Settings & Calibration Mode Features	19
8.2.1 Entering the Detectors Settings & Calibration Mode	20
8.3 Exit Menu	20

8.4 Zero Point Calibration	21
8.4.1 Perform Zero Point Calibration	21
8.4.2 Failed Zero Point Calibration	21
8.5 Span Gas Select	22
8.6 Span Point Calibration	22
8.6.1 Perform Span Point Calibration	22
8.6.2 Failed Span Point Calibration	23
8.7 Analogue Output Scale	23
8.8 Alarm Threshold	23
8.9 Latching	24
8.10 LED Brightness	24
9 Maintenance	24
9.1 User Maintenance	24
10 Specifications	26
11 Appendix	26
12 Revision History	28

1 Proprietary

1.1 Statement

The Gas Detection (Australia) iR-gas Series gas detector described in this document is the property of Gas Detection (Australia) Pty Ltd. It is furnished under a license agreement and is to be used only in accordance with the terms of the agreement.

No part of the hardware or documentation may be reproduced, transmitted, transcribed, stored in a retrieval system, or translated into any language or computer language, in any form or by any means, without prior written permission of Gas Detection (Australia) Pty Ltd.

1.2 Disclaimer

While Gas Detection (Australia) Pty Ltd has made every effort to assure the accuracy and clarity of this manual, we assume no liability resulting from any omissions in this document, or from misuse of the information contained within it. The information contained with this document has been carefully checked and is believed to be entirely reliable with all the necessary information included. Gas Detection (Australia) Pty Ltd reserves the right to make any changes and update this document whenever it deems necessary with no obligation to notify any person or company of the revisions or changes. The newest and most updated Documents will be available to download on www.gasdetectionaustralia.com.au. Gas Detection (Australia) Pty Ltd does not assume any liability arising out of the application or any use of any product of circuit described herein; neither does it convey license under its patent rights or the rights of others.

2 Warnings, Cautions and Notes

The detector must be installed within 30 days of purchase to retain the calibration certificate.

For safety reasons, the iR-gas Carbon Dioxide gas detector must be installed, operated, and serviced only by competent personnel. To avoid instrument damage please read the manual before operating or servicing this product. Do not disassemble your detector, there are no user serviceable parts inside, refer all servicing repairs to Gas Detection (Australia) Pty Ltd. These detectors use critically aligned optical benches and should not be subjected to vibration or mechanical shock. **Do not mount on a vibrating surface.** This detector is not designed for outdoor use. Handle with care.

THIS PRODUCT IS NOT SUITABLE FOR USE IN A HAZARDOUS AREA.

3 Introduction

3.1 Purpose And Contents of Manual

This manual contains installation operation and servicing instructions for the GDA iR-gas Series gas detector. Users of this product should read and understand the contents of this manual to gain safe use and optimum performance from the product.

3.2 Product Identification

The product name is GDA iR-gas Carbon Dioxide Gas Detector.

The serial number of the unit is located on the right side and on the inside of the enclosure. The target gas that the Detector is calibrated to is also printed on the serial number label.

3.2.1 Contents of Package

The package should contain:

- iR-gas series Carbon Dioxide Gas Detector
- User manual
- Calibration Certificate

The documentation will be in one booklet if there are multiple units purchased.

3.2.2 Enclosure

The iR-gas Carbon Dioxide Gas Detector is in a wall mounted enclosure. The sensing element protrudes from the bottom of the detector's enclosure. Gland holes will be required to be drilled in the enclosure for cable entry.



3.3 Product Description

3.3.1 Purpose of Product

The iR-gas Carbon Dioxide Gas detector's function is to detect the presence of Carbon Dioxide gas in the air surrounding it by diffusion. The iR-gas detector is designed to connect to a GDA Gas detection controller or similar BMS system to control alarm systems and/or ventilation to warn of gas loss and potential harmful situations.

3.3.2 Description of Operation

The iR-gas Carbon Dioxide Gas detector is a 3-wire 4-20 milliamp (mA) device with a failsafe volt free relay which energises at a set gas concentration threshold or on fault.

This product contains a Non-Dispersive InfraRed (NDIR) gas sensor. This is completely designed and manufactured at the N.E.T. headquarters in Milan, Italy and our staff is constantly working to extend it, improve it and optimize it. We now offer the most extensive NDIR range on the market. All sensors run on a microprocessor-based platform for internal signal processing, providing a linearized and temperature compensated output in digital and analogue format – this makes our IR sensors the ideal solution for instrument manufacturers like GDA.



The detector has a removable four pin connector providing connection to positive supply (24 VDC), zero-volt supply, mA current output and an Earth pin for the cable shield.

The mA current output provides the measurement signal which is proportional to the gas concentration over the detector's range typically 0-5% vol. or 0-1% vol.

The detector has a setting and calibration menu which includes an option to select the output scale choosing between 0-20 mA and 4-20 mA. The 0-20 mA can be converted to 0-10 volts with a resistor.

There is a failsafe volt free relay which will de-energise at a set gas concentration threshold, this is set by a small potentiometer and voltmeter. Three relay terminals are available Common, Normal Open, and Normal Closed.

Gas characteristics, air flow, concentration of leaked gas, volume of room, etc. all contribute to the detectors ability to detect Carbon Dioxide gas.

4 Installation

4.1 Installation Recommendations

Before installation read this manual thoroughly paying a close attention to aspects of the detector that may affect reliability and accuracy. Ensure a full understanding of the detectors technical specifications and compatible system requirements are met before installation.

- Cable entry is determined by the installer using desired entry location and gland size.
- Do not drill additional holes in the enclosure.
- Mount the detector approximately 300 mm from the floor.
- Install detector close to potential gas leak area
- Mount in an accessible location for function tests and calibration
- Use secure fixings to mount the detector to a solid vertical surface
- Do Not mount on a medium to high vibrating surface
- Vibrations may shorten the detectors life or cause false readings
- Allow a minimum of 1.0 meter in front of detectors gas inlet to ensure adequate air movement
- This detector is designed for indoor use away from dripping water
- It is important to ensure that the cable entry point is watertight especially if using top entry
- Observe the specifications to ensure that the correct supply voltage and polarity are used.
- The detector has reverse polarity protection, but not observing the correct polarity could cause damage to the detector or attached equipment and void the warranty.
- Observe any workplace regulatorily concerning detector quantity and placement

4.2 Mounting the Enclosures

The detector's enclosure is to be mounted on a flat vertical surface with four appropriate screws/bolts for the application. The enclosure fixing holes are 5.75 mm in diameter accommodating up to a M5 screw/bolt. The enclosure's IP rating is maintained when the detector is mounted with the sensor facing towards the floor. Mounting the detector with the sensor facing towards the ceiling will compromise the detectors ability to sense CO2 gas accurately.



4.2.1 Dimensions



4.3 Electrical Connections

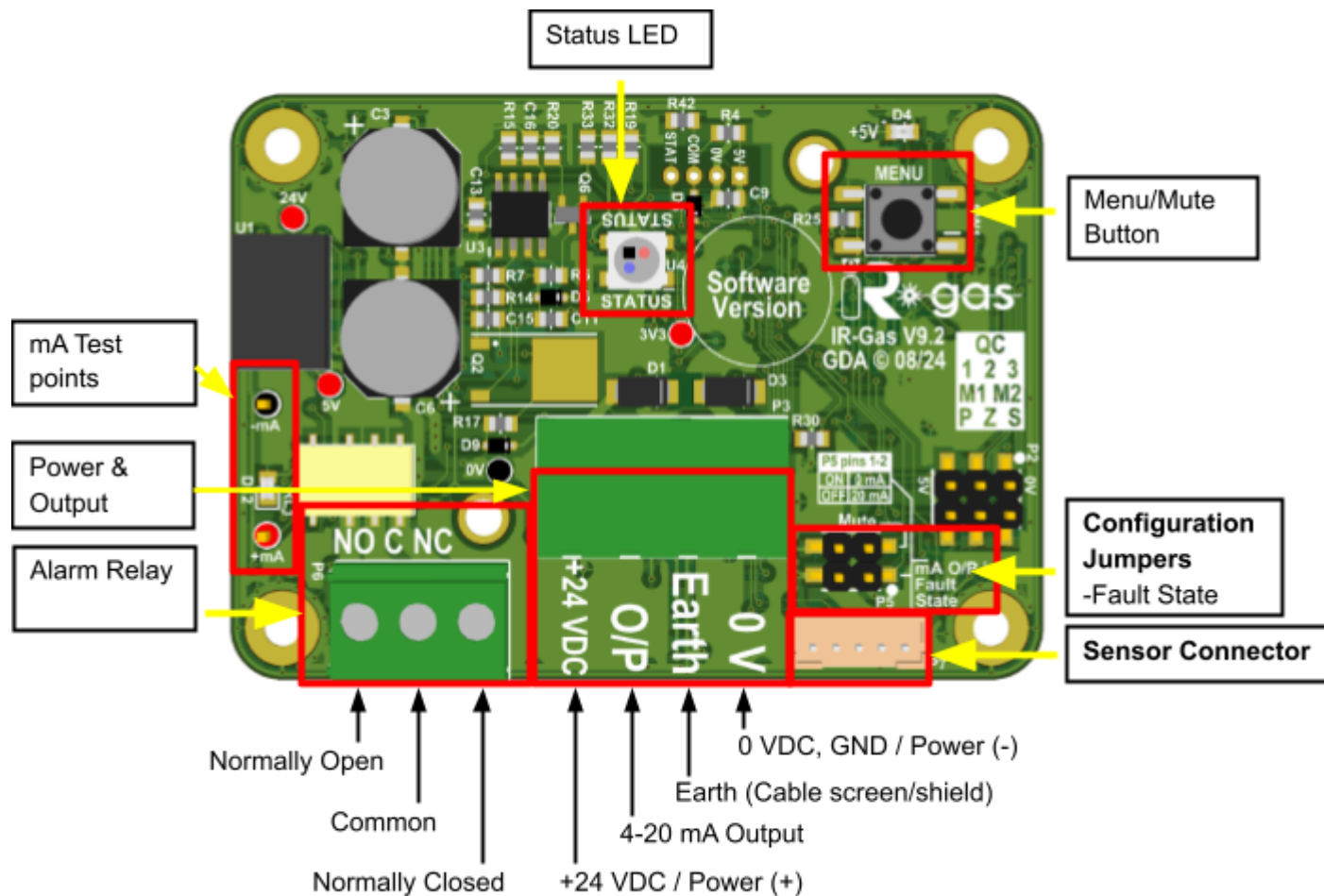

4.3.1 Installation Cable Choice

Use a 3 core shielded or 2-twisted pair cable to connect the detector to the controller.

Electrical connections of Power connector.

Terminal	Description	Notes
+24 VDC	+24 VDC / Power (+)	Positive supply voltage 24 VDC
O/P	4/0-20 mA / 0-10 VDC output	Configured as 4-20 mA from factory
Earth	Cable screen/shield	Provides noise protection
0V	0 VDC, GND / Power (-)	Negative supply voltage 0 VDC

Electrical connections of Relay connector.

Terminal	Description	Note
NO	Normally Open	Relay operates in Fail safe mode
C	Common	
NC	Normally Closed	

A volt free alarm relay activates when the CO2 gas rises above the set threshold, this is set by the alarm level adjustment pot in section 5.3.6, see section 10 for digital output specifications.

4.3.2 Cable Shield

The cable shield should be used to reduce EMI noise by using the earth terminal on the detector and the controller. If the controller does not have an earth terminal the shield will need to be connected to the earth of the system's power supply. Ensure that no earth loops are created.

*Not Connected: Prevent loops in the 0V connection.

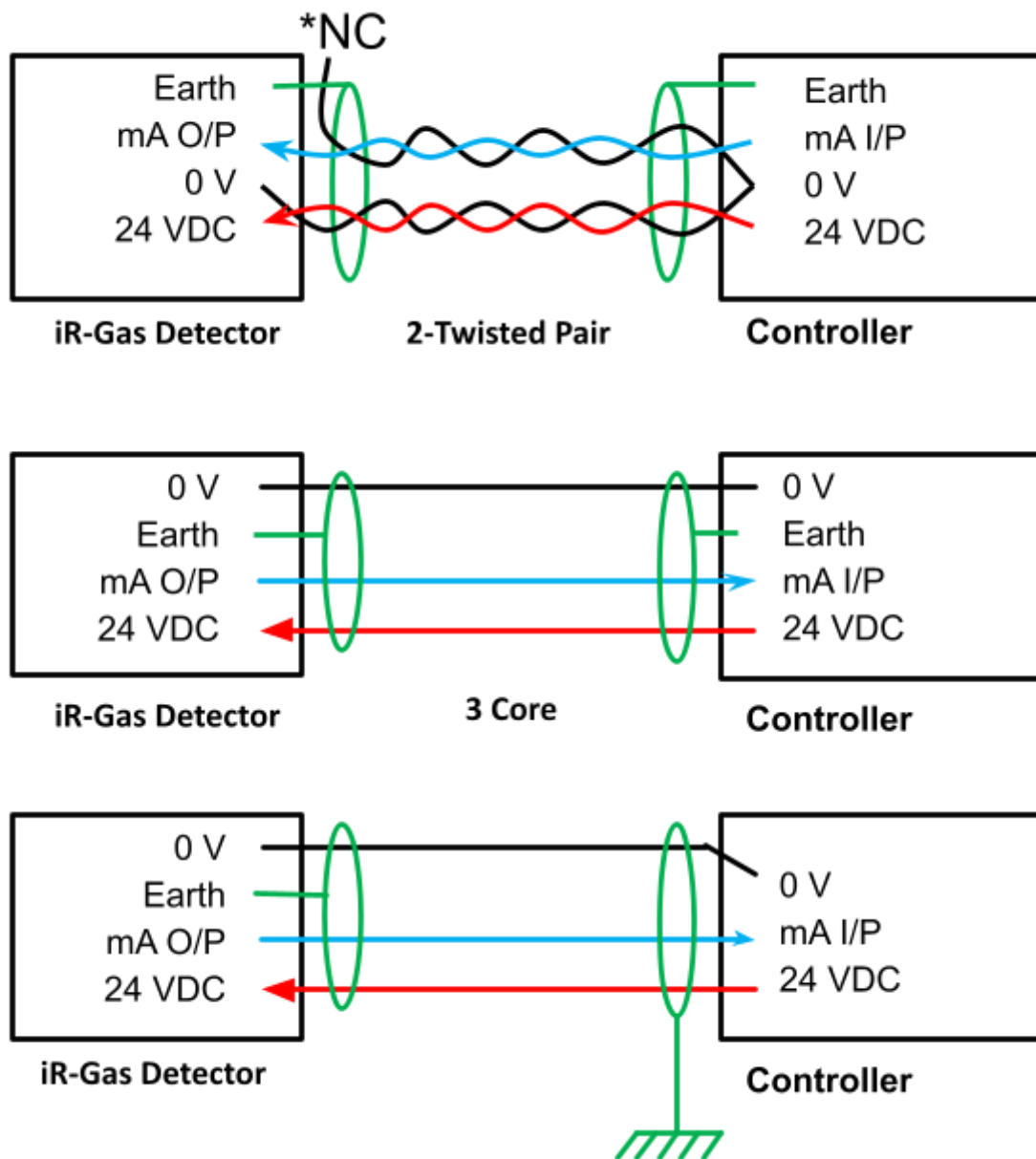

4.3.3 Cable Gland

The enclosure base is blank, enabling the gland entry to be chosen by the installer.

AVOID TOP ENTRY CABLE GLAND WERE POSSIBLE. Use of sealed cable glands in top entry is required. Sensors have been destroyed by water from condensation in top entry conduit cable glanding.

4.3.4 0-10 V Output

To convert the output of the detector from current to voltage a resistor is required to be connected across the input of the controller. This is so that the 0-20 mA signal is transmitted over the cable distance and converted to the 0-10 V at the controller. This is to take advantage of the noise reduction ability and the lack of voltage drop of the mA transmission. Below is a table of the common load resistor values for converting a current to voltage output. See figure in section 8.7 for how to change the detectors mode from 4-20 mA to 0-20 mA output.

Load Resistor values for voltage out.

Resistor	0-20 mA Output	4-20 mA Output
100 Ω	0 - 2 V	0.4 - 2 V
250 Ω	0 - 5 V	1 - 5 V
500 Ω	0 - 10 V	2 - 10 V

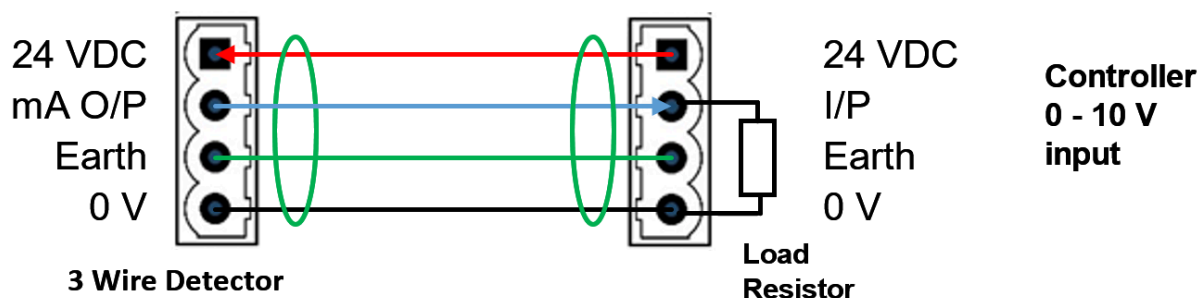

5 Functions

5.1 Status LED

The status RGB LED displays the status of the detector; indicating normal operation, fault conditions, gas concentration, and menu levels. In the menu system the detector provides two user interfaces; RGB LED, and mA output (via test points or mA output). See section 8.2 for a diagram showing the menu system LED colour.

5.2 Menu/Mute Button

The iR-gas CO₂ gas detector has a simple menu system that can be accessed with a single button, by pressing the button on the Printed Circuit Board (PCB).

To enter the menu press and hold the button for at least 1.5 seconds and release the button 3 times in a row to access Calibration Mode. If successful, the LED colour will change to indicate the menu system. See section 8.2 for further information.



5.3 Configuration Jumpers

5.3.1 Mute

The Mute function does not apply for this model.

5.3.2 Fault State mA Output

When the sensor is in a fault condition the output will change depending on the position of the jumper. When the jumper is in the output will go to 0 mA and if the jumper is off the output will be 20 mA

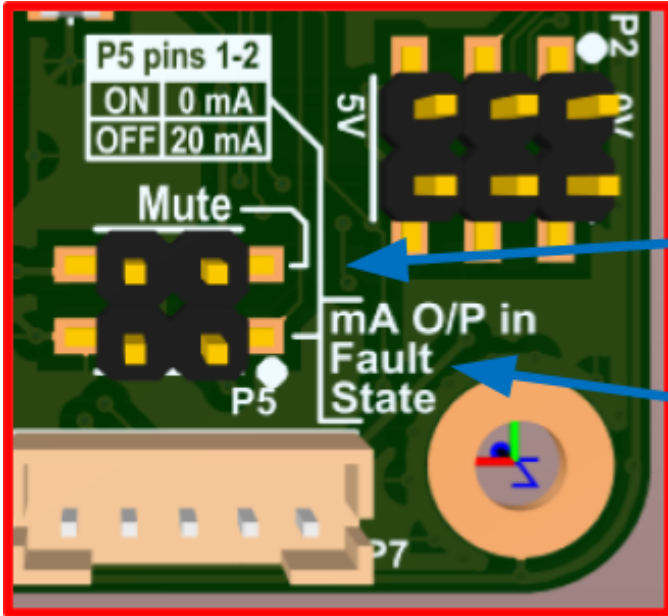

Mute
Jumper in = Always Muted
Jumper out = Able to Mute with button

Fault State mA output
Jumper in = Fault State 0 mA
Jumper out = Fault State 20 mA

5.4 mA Test Points

These test points are used to observe the mA output of the detector. The mA output represents the detector's output range of 0-5% vol. over the 4-20 mA or 0-20 mA range. Therefore 0% vol. = 0 or 4 mA and 5% vol. = 20 mA. To use the mA test points the detector is required to be connected to a load. To measure the mA output of the sensor, set a Digital Multimeter (DMM) to mA range and connect the leads with alligator clips to the test points. The output can also be measured by placing the DMM in line with the mA signal.

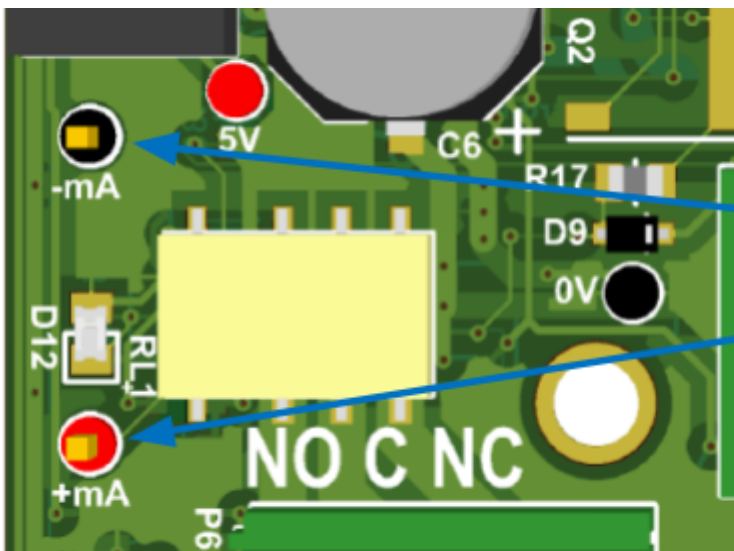

mA Test points

5.5 Alarm Level Relay Setting

The alarm relay is set to 0.5% vol. for the 0-5% vol. model and 2500 ppm for the 0-1% vol. model from the GDA factory. If a different alarm level is required to trigger the relay it can be selected from any value in the table for the device's range.

The Alarm can be disabled by selecting the RED/4 mA option. The relay, buzzer and front red LEDs will not activate in alarm condition but will still activate in a fault condition. All listed currents for 4-20 mA configuration.

	Alarm Threshold Number and LED Colour							
Sensor Range	1	2	3	4	5	6	7	8
2000 ppm	Disabled 4 mA	600 ppm 8.8 mA	800 ppm 10.4 mA	1000 ppm 12 mA	1200 ppm 13.6 mA*	1400 ppm 15.2 mA	1600 ppm 16.8 mA	1800 ppm 18.4 mA
5000 ppm	Disabled 4 mA	600 ppm 5.92 mA	800 ppm 6.56 mA	1200 ppm 7.84 mA	1600 ppm 9.12 mA*	2500 ppm 12 mA	3500 ppm 15.2 mA	4500 ppm 18.4 mA
10000 ppm (1% vol.)	Disabled 4 mA	600 ppm 4.96 mA	800 ppm 5.28 mA	1200 ppm 5.92 mA	2500 ppm 8 mA*	3500 ppm 9.6 mA	5000 ppm 12 mA	7500 ppm 16 mA
50000 ppm (5% vol.)	Disabled 4 mA	800 ppm 4.256 mA	1200 ppm 4.384 mA	2500 ppm 4.8 mA	5000 ppm 5.6 mA*	1.5% vol. 8.8 mA	2.5% vol. 12 mA	3.0% vol. 13.6 mA
20% vol.	Disabled 4 mA	1.5% vol. 5.2 mA	2.5% vol. 6 mA	3% vol. 6.4 mA	5% vol. 8 mA*	10% vol. 12 mA	15% vol. 16 mA	18% vol. 18.4 mA
100% vol.	Disabled 4 mA	5% vol. 4.8 mA	15% vol. 6.4 mA	30% vol. 8.8 mA	50% vol. 12 mA*	65% vol. 14.4 mA	80% vol. 16.8 mA	90% vol. 18.4 mA

* Factory Default Alarm.

6 Verification of Installation

The Verification of Installation procedure is performed after the iR-gas detector has been installed and electrically connected.

Ensure that the power to the detector(s) is switched off at the controller.

- Visually check that the mechanical mounting of the detector is correct as to details in this manual.
- Visually check that the electrical connections within the detector are correct. Conductors should be marked / colour coded and their function must match those given in the Electrical connections Table in section 4.3.1 of this manual.
- Visually check that the electrical connections at the controller match the function of the Electrical connections Table in section 4.3.1 of this manual. And that the conductor markings correspond correctly to those at the detector.
- Isolate the power to the detector (temporarily unplug the detector connector at the controller).
- Isolate any alarms.
- Turn on the system power and check that the supply voltage from the controller system meets the requirements given in the specifications table in section 10.
- Turn off the power and reconnect the detector at the controller.
- Turn the power on to power the detector
- Please note: Following power on the detector goes through a self-check and initialization sequence of approximately 60 seconds during this period do not press the button. After a 5-minute warmup the detector is able to detect gas at its stated accuracy.
- Following warmup check that the power supply is still within specification.
- Allow the system to settle for at least 60 minutes for the temperature to stabilise.
- Observe the controller readings from the detector and ensure that they are as expected. For Carbon Dioxide gas the reading should be approximately 400 ppm. Ensure that the area around the detector is free of Carbon Dioxide sources.
- Observe that the detector reading is stable.

7 Commissioning

7.1 Initial Commissioning

It is necessary to commission your newly installed iR-gas detectors.

Full system commissioning is not covered in this manual as every installation is different.

Below is a recommended sequence of checks to ensure correct operation of the detector.

A basic system will have a gas detector, controller and alarms.

Notify the appropriate people that the alarms will be activated during the commissioning process.

The detector must be bump tested with the target gas. The recommended minimum concentration of the bump test gas is 25% above the required alarm level. Apply gas with a gassing cap for 3 minutes at 0.2-0.3 LPM flow rate.

Observe that the sensor is now showing gas detected by the LED Colour changing from Green to Yellow and then Red when in alarm. Also you will want to check your controller / BMS unit at this point to make sure that it is also showing the correct gas concentration and alarm level.

Walk around and check that all alarms are functioning correctly.

Testing of the Fault condition is also required for correct commissioning.

To cause a fault condition you will want to disconnect the newly installed sensor and then see the state of the controller to make sure your FAULT condition is working correctly.

If you require commissioning, please contact Gas Detection (Australia) Pty Ltd on (07) 4613 5111.

7.2 Function Checks

Function tests are a required check to make sure that your investment is working correctly and people and machinery are safe to rely on this equipment. **Function tests should be carried out every 6 months.**

7.2.1 Equipment required for Function Checks

Certified Gas:	For 5% vol. Detector use 3% vol. - 5% vol. of certified calibration gas For 1% vol. Detector use 0.5% vol. - 1% vol. of certified calibration gas For 20% vol. Detector use 4% vol. - 15% vol. of certified calibration gas
Regulator:	0.2-0.5 LPM
Tube:	Tygon E-3603 (Recommend)
Gassing Cap:	Available from GDA; GC-IRCO2

7.2.2 Bump Test Conditions

Bump test may be carried out with a suitable test gas to ensure that the 4-20 mA o/p and the built in relay corresponds with the gas level. This should be undertaken when the unit is fully assembled and using a flow rate of 0.2-0.3 LPM of the target gas. The detector requires a 60 min warm up period before you commence the Bump Test.

Test gas and equipment are available from Gas Detection Australia.

7.2.3 Bump Test Procedure

- Connect the regulator to the cylinder of calibration gas
- Attach the tube to the regulator and gassing cap
- Attach the gassing cap to the detector
- Flow the certified gas at 0.2-0.5 LPM for 3 minutes
- Observe that the LED light patterns have changed on the detector from flashing green to flashing green and yellow to flashing green and red as the gas concentration increases.
- Check that the controller is showing the correct concentration approximating the cylinder concentration.

7.2.4 Failure of Bump Test

- Check the cylinder and tube connections and that the gassing cap is fitted securely to the detector with no gaps.
- Check that the flow rate of the regulator is 0.2-0.5 LPM
- If the detector fails a bump test then you will need to calibrate the detector as per section 8.

7.2.5 Fault Condition

The detector will indicate a fault with a flashing magenta LED.

8 Calibration Procedure

Calibration of your detector is required **annually** or sooner if it fails at your 6 monthly Bump Test.

8.1 The Purpose of Calibration

You need to calibrate your detector to ensure it is working correctly and keeping staff and equipment safe and working efficiently. If your detector is not working properly then you may risk losing gas and also causing injury to staff and visitors. Inherently detectors will have an amount of Drift over time, this is also a reason that Bump testing and Calibrations are required. Calibrating your detector will make sure you are always safe and your equipment is kept in the best possible working order.







8.1.1 Preparing for Calibration

Certified Gas: Zero point calibration gas is Nitrogen (N₂) 4.0 - 5.0 (99.99 - 99.999% vol)
Span point calibration gases are in the table below.

Regulator: 0.2-0.3 LPM

Tube: Tygon E-3603 (SKU: 64030)

Gassing Cap: E-Sense and iR-gas-CO₂ gassing cap (SKU: 65270)

Span point calibration gas in reference to selectable gas bottles in section 8.5				
Gas Bottle Number	LED Colour	10000 ppm (1% vol.)	5% vol. (50000 ppm)	20% vol.
1		2000 ppm, (7.2 mA)	1.0% vol. 7.2 mA	4.0% vol. (7.2 mA)
2		2500 ppm, (8.0 mA)	2.5% vol. 12.0 mA	5.0% vol. (10.4 mA)*
3		3000 ppm, (8.8 mA)	3.0% vol. 13.6 mA*	10% vol. (12 mA)
4		5000 ppm, (12.0 mA)*	3.5% vol. 15.2 mA	15% vol. (16 mA)
5		-	4.0% vol. 16.8 mA	-
6		-	-	-

***GDA factory set calibration gas bottle contractions.**

Make sure that the detector has been powered on and working for at least 60 minutes, this is to allow the detector's temperature to settle.

Make sure all personnel are notified that the alarms will be activated. (Some people may like to de-activate the alarms during this procedure).

8.2 Settings & Calibration Mode Features

iR-Gas V9.1.9.6 Settings & Cal

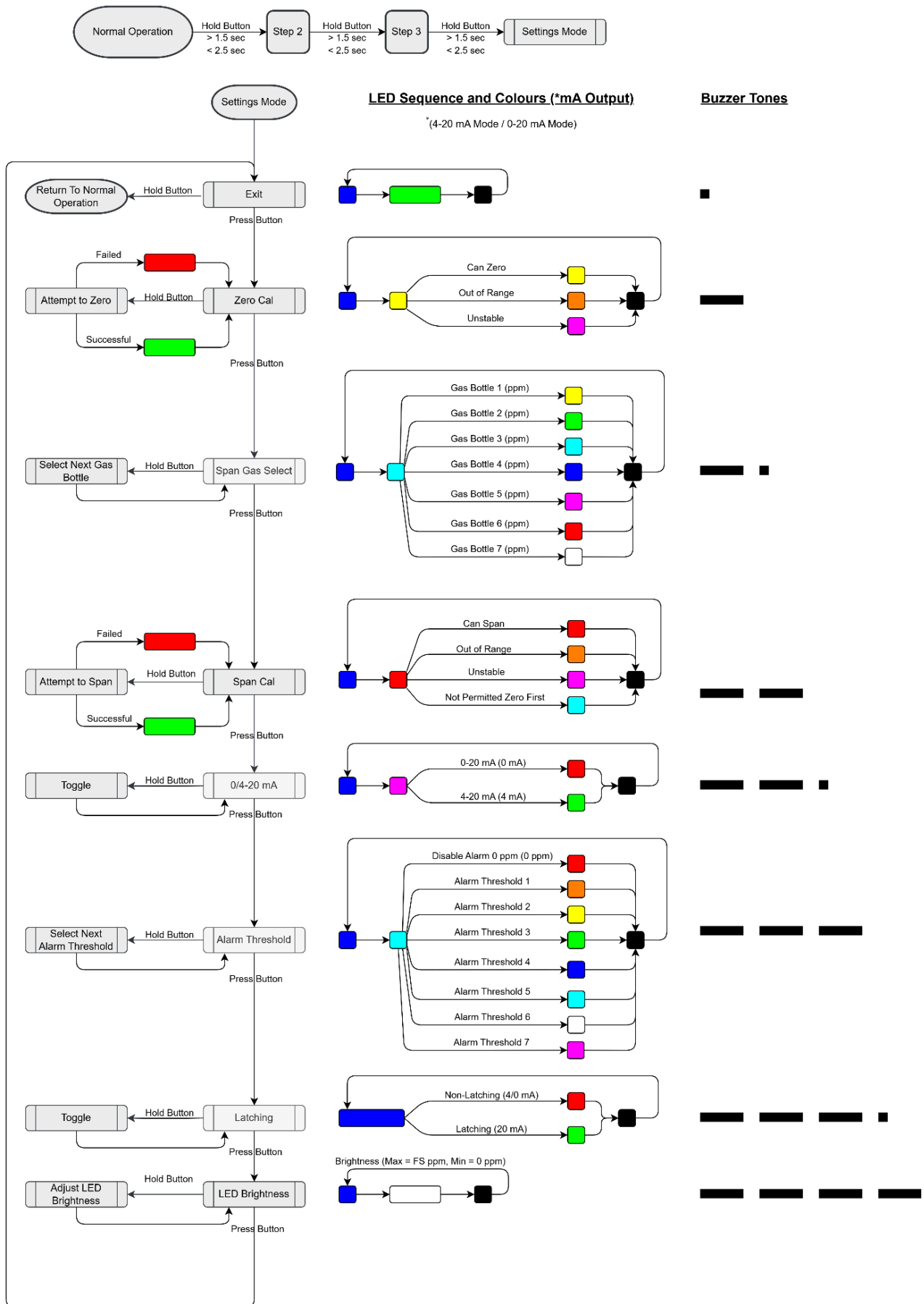

8.2.1 Entering the Detectors Settings & Calibration Mode

The iR-gas detector has a one button menu system for user settings and calibration.

Menu Settings in order of entering the settings mode:

1. Menu Exit Section 8.3
2. Zero Calibration Section 8.4
3. Span Gas Select Section 8.5
4. Span Calibration Section 8.6
5. 0/4-20 mA Output Section 8.7
6. Alarm Threshold Section 8.8
7. Latching Section 8.9
8. LED Brightness Section 8.10

To place the detector into settings mode press and hold the front menu button for 1.5 - 2.5 seconds, release and repeat for a total of 3 times (see diagram below for details). If it does not enter continue the process till it enters the menu with the LED flashing blue and green. See the Appendix for buzzer sound patterns.

Button press sequence to enter menu.

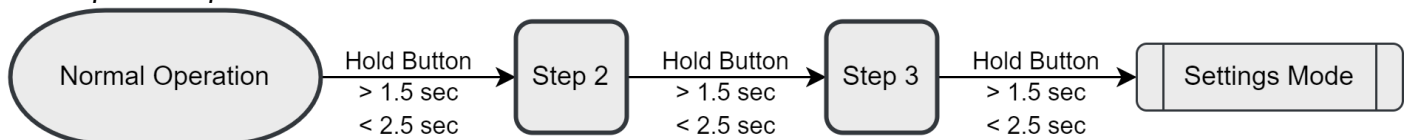

8.3 Exit Menu

This is the first option upon entering the settings mode. Press the button once to cycle through each setting. To exit, press and hold the button when the LED is blue and green or if left in settings mode the detector will automatically return to normal operation after approximately 10 minutes. The mA output will read the measured gas concentration, buzzer sound; one short beep on entering the setting.

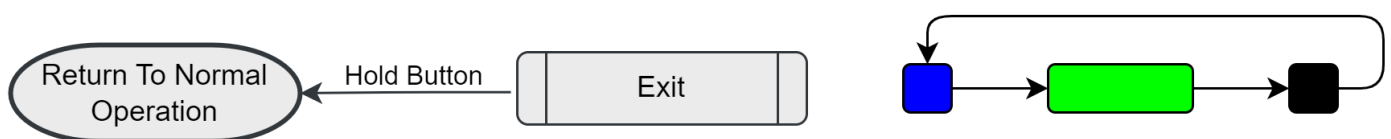

Press the button once to move to Zero Calibration mode.

8.4 Zero Point Calibration

Zero point calibration is to be set when there is a gas concentration of zero (0 ppm) of CO₂ gas delivered to the detector. We will refer to this gas as Zero gas. This point also represents the minimum range of the detector's output 4.00 mA (or 0 mA for 0-20 mA setting). The detector is to be powered for a minimum of 1 hour in its installed location to stabilise its temperature and pressure. After 1 hr if the detector is power cycled for a short period a warm up of 5 min is required to achieve full specification. Likewise if the detector is reset a warmup of 5 min is required to achieve full specification.

Zero calibration LED pattern.

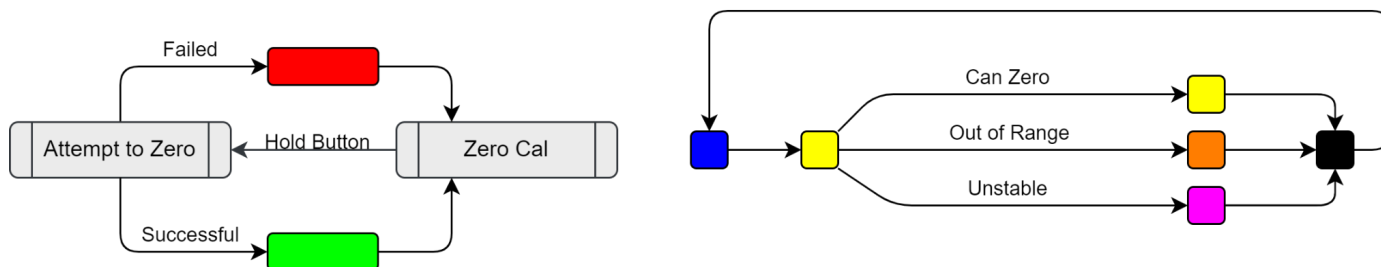

8.4.1 Perform Zero Point Calibration

- Once in Zero Calibration mode the LED should be flashing blue and yellow. If not, press the button until it flashes blue and yellow. The mA output will read the Actual gas concentration.
- Connect the regulator to the bottle of Zero calibration gas, Nitrogen.
- Attach the tube to the regulator and gassing cap.
- Attach the gassing cap to the detectors brass or stainless steel sensor housing firmly.
- Flow the gas for 5 minutes at 0.2-0.3 LPM. (Continue to flow gas over the detector until a successful calibration).
- The LED pattern will change as the detector checks if the gas concentration is within its Zero calibration range (orange LED). See the diagram above for the LED patterns.
- A magenta LED indicates that the gas concentration is not stable enough to calibrate.
- Allow the detector's output to stabilise, this can be checked on the controller or using a DMM on the mA test points.
- A yellow and blue flashing LED indicates that the detector is stable and is able to be calibrated.
- Once stable press and hold the button to perform the Zero calibration.
- The LED will flash green when successfully calibrated.
- Once satisfied with the calibration, press the button once to proceed to the Span calibration mode.
- The gassing cap can remain on the detector if a Span calibration is to follow, turn off the Zero gas.
- Or to exit Calibration mode press the button till the LED flashes blue and green then press and hold the button to return to normal operation.
- Turn off gas and remove the gassing cap.

8.4.2 Failed Zero Point Calibration

If the detector fails to calibrate it will flash the LED red.

Before reattempting Zero calibration check the following.

- Ensure the detector is in Zero calibration mode (see LED diagram).
- Check the colour of the LED to determine the state of the detector.
- Ensure that the detector has been powered for the absolute minimum time.
- Continue to observe the LED colour pattern and reattempt calibration when the LED is yellow.
- If LED continues to flash magenta (unstable) check the equipment connections and firm fitment of the gassing cap.

8.5 Span Gas Select

The Span gas concentration is factory set to 5000 ppm (12.0 mA) on the 1% vol. version and 3% vol. (13.6 mA) on the 5% vol. version. To select a different calibration concentration ensure that the LED is flashing blue and orange the third colour will indicate the current gas bottle. The bottle number can also be observed with a DMM. To change the gas bottle press and hold the button and observe the LED and mA change to the required concentration according to the table in section 8.1.1.

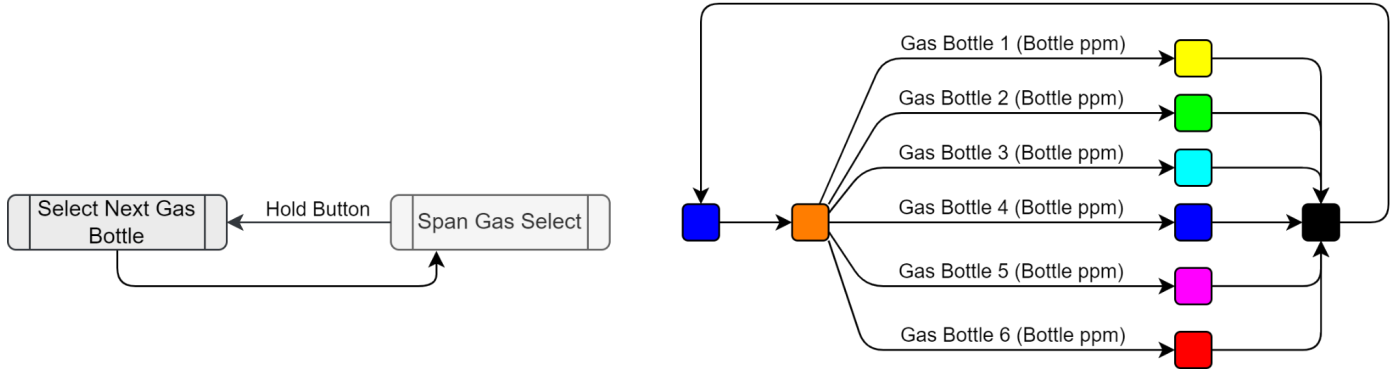

8.6 Span Point Calibration

Span point calibration can only be performed when there is a gas concentration close to the gas bottle value selected in section 8.5. The Span point also represents the mA output of the detector noted in the table in section 8.1.1.

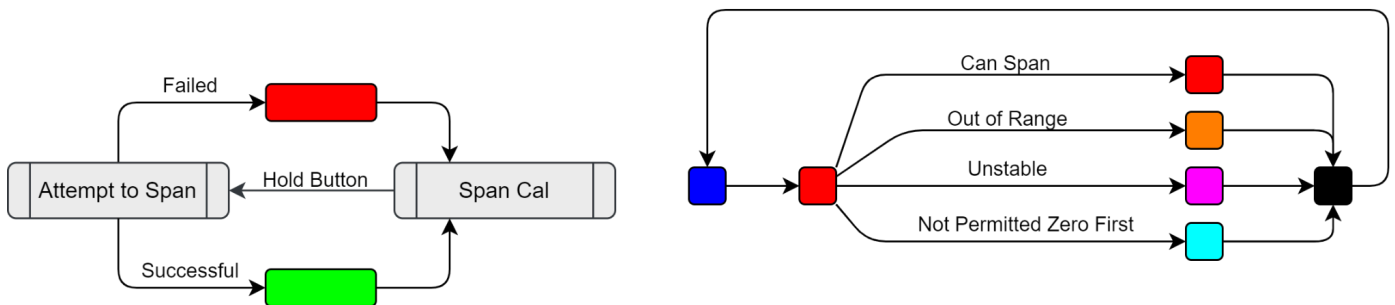

8.6.1 Perform Span Point Calibration

- Press the button once to select Span calibration mode, the LED should change to flashing blue and red. The mA output will read the Actual gas concentration.
- Connect the regulator to the bottle of Span calibration gas.
- Attach the tube to the regulator and gassing cap.
- Attach the gassing cap to the detectors brass or stainless steel sensor housing firmly.
- Flow the gas for 5 minutes at 0.2-0.3 LPM. (Continue to flow gas over the detector until a successful calibration).
 - The LED pattern will change as the detector checks if the gas concentration is within its Span calibration range (orange LED). See the diagram above for the LED patterns.
 - A magenta LED indicates that the gas concentration is not stable enough to calibrate.
- Allow the detector's output to stabilise, this can be checked on the controller or using a DMM on the mA test points.
- A red and blue flashing LED indicates that the detector is stable and is able to be calibrated.
- Once stable press and hold the button to perform the Span calibration.
- The LED will flash green when successfully calibrated.
- Once satisfied with the calibration, to exit Calibration mode press the button till the LED flashes blue and green then press and hold the button to return to normal operation.
- Turn off gas and remove the gassing cap.

8.6.2 Failed Span Point Calibration

A failed Span calibration is indicated by a long red flash of the LED. Leave gas flowing while reattempting span calibration.

- Continue to observe the LED colour pattern and reattempt calibration when LED is flashing red and blue.
- If LED continues to flash magenta check the equipment connections and firm fitment of the gassing cap.
- reattempt span calibration when the LED pattern is stable red and blue with no magenta.

8.7 Analogue Output Scale

To change the analogue output from 4-20 mA to 0-20 mA press and hold the button when the LED is flashing blue and magenta. The default setting is 4-20 mA indicated as the LED flashing blue, magenta and green. While in this menu the mA output will read 4 mA for 4-20 mA output and 0 mA for 4-20 mA output.

Recalibration of the detector is NOT required when changing the analogue output scale.

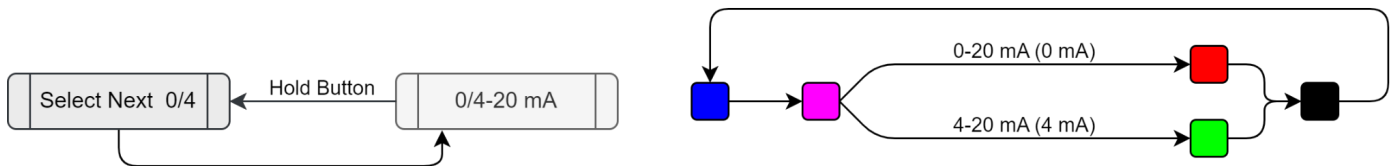

8.8 Alarm Threshold

The Alarm Threshold will be indicated by the flashing blue, cyan and selected colour LED. To change the alarm threshold press and hold the button. The alarm relay is set to 0.5% vol. for the 0-5% vol. model and 2500 ppm for the 0-1% vol. model from the GDA factory. If a different alarm level is required to trigger the relay it can be set to any of the following thresholds in the table below, or disabled. Note, disabling the alarm doesn't disable the fault from triggering the relay. The mA output will correspond to the currently selected alarm threshold. The mA values given are for 4-20 mA output range only.

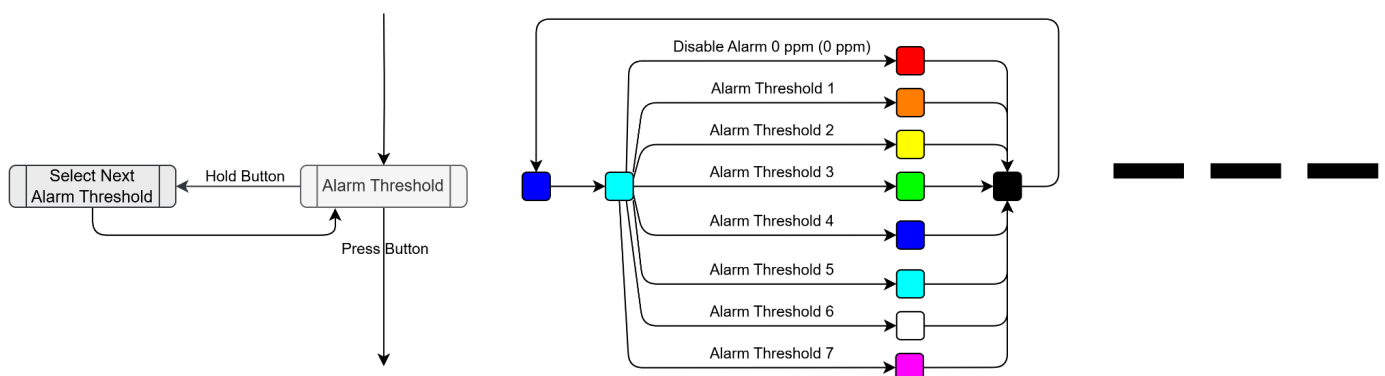

	Alarm Threshold Number and LED Colour							
Sensor Range	1	2	3	4	5	6	7	8
2000 ppm	Disabled 4 mA	600 ppm 8.8 mA	800 ppm 10.4 mA	1000 ppm 12 mA	1200 ppm 13.6 mA*	1400 ppm 15.2 mA	1600 ppm 16.8 mA	1800 ppm 18.4 mA
5000 ppm	Disabled 4 mA	600 ppm 5.92 mA	800 ppm 6.56 mA	1200 ppm 7.84 mA	1600 ppm 9.12 mA*	2500 ppm 12 mA	3500 ppm 15.2 mA	4500 ppm 18.4 mA
10000 ppm (1% vol.)	Disabled 4 mA	600 ppm 4.96 mA	800 ppm 5.28 mA	1200 ppm 5.92 mA	2500 ppm 8 mA*	3500 ppm 9.6 mA	5000 ppm 12 mA	7500 ppm 16 mA
50000 ppm (5% vol.)	Disabled 4 mA	800 ppm 4.256 mA	1200 ppm 4.384 mA	2500 ppm 4.8 mA	5000 ppm 5.6 mA*	1.5% vol. 8.8 mA	2.5% vol. 12 mA	3.0% vol. 13.6 mA
20% vol.	Disabled 4 mA	1.5% vol. 5.2 mA	2.5% vol. 6 mA	3% vol. 6.4 mA	5% vol. 8 mA*	10% vol. 12 mA	15% vol. 16 mA	18% vol. 18.4 mA
100% vol.	Disabled 4 mA	5% vol. 4.8 mA	15% vol. 6.4 mA	30% vol. 8.8 mA	50% vol. 12 mA*	65% vol. 14.4 mA	80% vol. 16.8 mA	90% vol. 18.4 mA

* Factory default alarm value.

8.9 Latching

Latching will be indicated by the long flashing blue, and either a green or red colour LED. The red indicates non-latching operation and green indicates latching operation. Press and hold the button to toggle whether faults and alarms are latched on the relay. When latching is enabled all alarms and faults are required to be unlatched to release the relay via the button. When latching is disabled the alarm will self clear when below the alarm point and hysteresis. And faults will remain for at least two minutes and will clear the fault alarm if the fault condition has been cleared within that time.

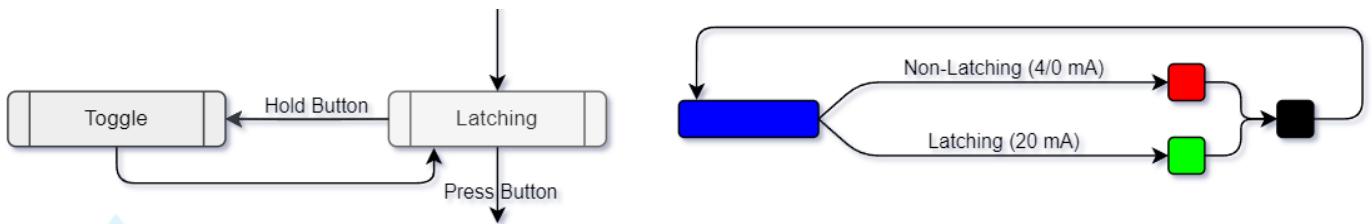

8.10 LED Brightness

The RGB LEDs brightness can be changed in this setting. When the LED is flashing blue and white press and hold the button and the brightness will change in steps as the button is held, release the button to select the current brightness. The mA output will read the measured gas concentration.

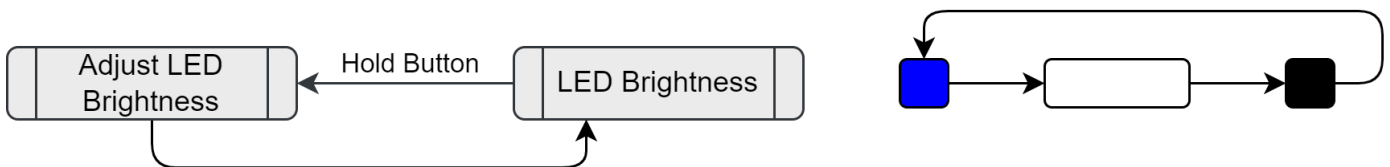

9 Maintenance

9.1 User Maintenance

It is the recommendation from GDA that the detector has a bump test period in accordance with the building requirements of where it is installed. It is recommended that the minimum bump test period is 6 months and a recalibration of the Zero and Span point annually with certified calibration gas.

Ensure the detector opening is kept free of anything that may cause a reduction of air movement into the detector.

10 Specifications

Model	iR-gas-CO2-1, iR-gas-CO2-5
Detectable Gas Range	0-1% vol., 0-5% vol.
Measuring Units	% vol. or ppm
Sensor Technology	Non Dispersive Infra-Red (NDIR), dual beam technology
Sensing Method	Diffusion
Service Frequency	Bump Test 6 months
	Calibration 12 months
Response Time	T50 ≤ 8 s; T90 ≤ 30 s
Warm Up Time	< 5 minutes @ 25 °C
	> 60 minutes (full specification) @ 25 °C
Resolution	0.2% of Full Scale range ppm
Accuracy @ 25 °C, 1000hPa	±1% of FS range for readings below 25% of range ±2% of FS range for readings below 50% of range ±5% of FS range above 50% of range
Zero Calibration Gas	Nitrogen (N2) 3.0 - 5.0 (99.9 - 99.999% vol.)
Span Calibration Gas Selectable	iR-gas-CO2-1; 0.2, 0.25, 0.3, 0.5% vol. iR-gas-CO2-5; 1.0, 2.5, 3.0 , 3.5, 4.0% vol. (Factory set)
User Interface Type	Settings & Calibration Button. For Tech Menu access contact GDA
Supply Voltage	24 VDC ±10%
Outputs	1 x Analogue, 1 x Digital
Output Specifications	0-20 mA, 4-20 mA (4-20 mA Default). 0-10 V with a Resistor
Analogue Output Specifications	4-20 mA (580 ohms max load)
Digital Output Specifications	1 A @ 24 VDC, 1P2T, Volt-Free Relay
Alarm Relay Range	5 to 90% of range
Dimension	145 x 130 x 72 mm (L x W x D)
Weight	350 g
Material	ABS Plastic
Mounting	Wall Mount
Mounting Height	300-500 mm From Floor
Cable Entry	User defined
Operating Temperature	-40 to 60 °C
Storage Temperature	-40 to 85 °C
Operating Humidity	5 to 95 % RH (not condensing)
Operating Pressure	800 to 1200 mBar, Change in pressure will offset Calibration
IP Rating	IP64
Warranty	12 Months

11 Appendix

LED patterns of normal operation.



LED patterns for various states.

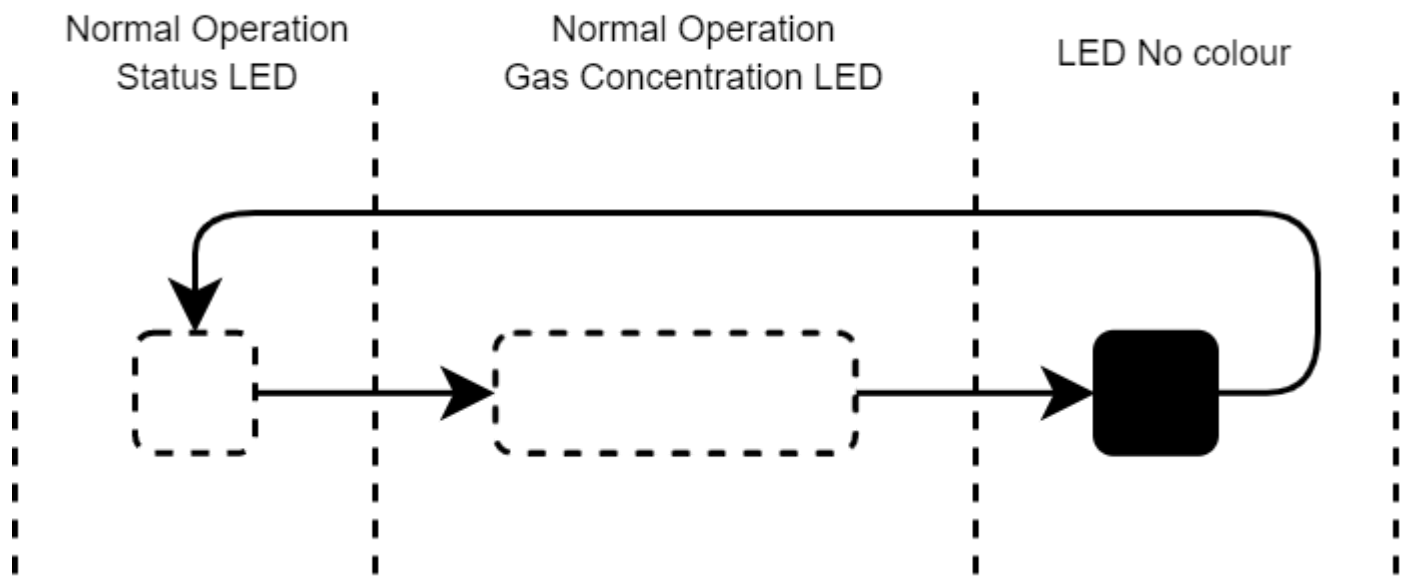

Normal Operation Status LED		Normal Operation Gas Concentration LED	
State	Colour	State	Colour
Warm-up	Blue	Under Range	Cyan
Normal/Idle	Green	No gas/Blanked	Green
Alarm	Red	Gas detected just above blanking window	Yellow
OverRange	Fault	Gas Detected	Yellow to Red proportional to %FS of gas concentration
		Gas concentration at full-scale	Red
		Gas concentration Over Range	Magenta

LED colour according to the detectors state.

Level Description	Concentration	Status Led with Alarms Enabled	Status Led with Alarms Disabled	Concentration	Buzzer & No Mute	mA O/P
Under Range	Concentration < Neg Blanck	Magenta	Green	Cyan	AL1	Fault Setting
Around zero within drift/blanking	Positive Blank > Concentration > Neg Blank	Green	Green	Green	None	0/4 mA
Detecting Gas	Concentration > Positive Blank	Green	Green	Yellow	None	0/4 mA
Detecting Gas Less than the alarm level	Concentration < Alarm Level	Green	Green	Yellow to Red proportional to %FS of gas concentration	None	Concentration
In Alarm	Concentration > Alarm Level	Red	Green	Yellow to Red proportional to %FS of gas concentration	AL2	Concentration
Over Range	Concentration > Range	Red	Green	Magenta	AL3	upto 21.5 mA
Fault	NA	Magenta	Magenta	Magenta	Fault	Fault Setting

12 Revision History

Version	Contents	Date
1.0	Initial version of the iR-gas CO2 Manual HW: V7.0.8.0	31 Mar, 2023
2.0	Updated to iR-gas hardware version 9.2	19 Dec, 2024
2.1	Corrected LPM values of regulators	20 Dec, 2024



1300 432 937

Gas Detection (Australia) Pty Ltd

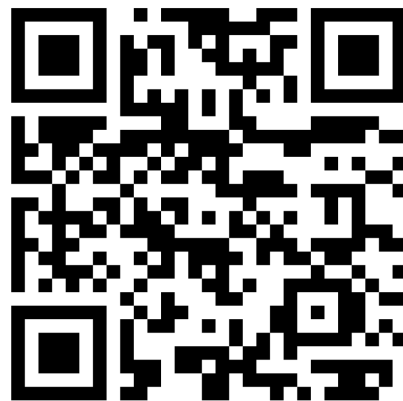

Suite 1, 218 Anzac Avenue, Harristown QLD 4350

sales@gasdetect.com.au
gasdetectionaustralia.com.au