

Two Channel Controller Operating Manual 4022



Thank you for purchasing the 4022 product from Gas Detection (Australia) Pty. Ltd.

This manual contains information about the method of installation, simple maintenance and troubleshooting. Please read it carefully and keep it nearby for further reference.

If you have any further question about the product, please contact us.

Location: Unit K1, USQ, Baker Street Toowoomba, QLD 4350

Address: PO BOX 597, Darling Heights, QLD 4350

Phone: 07 4613 5111

Web: www.gasdetectionaustralia.com.au

Email: sales@gasdetect.com.au

Throughout this document GDA and Gas Detection (Australia) Pty. Ltd. are used interchangeably.

PROPRIETARY RIGHTS

No part of the hardware or documentation may be reproduced, transmitted, transcribed, stored in a retrieval system, or translated into any language or computer language, in any form or by any means, without prior written permission of GDA.

While great efforts have been made to ensure the accuracy and clarity of this document, GDA assumes no liability resulting from any omissions in this document, or from misuse of the information contained herein. The information in this document has been carefully checked and is believed to be entirely reliable with all of the necessary information included. GDA reserves the right to make changes to any products described herein to improve reliability, function, or design, and reserves the right to revise this document and make changes from time to time in content hereof with no obligation to notify any persons of revisions or changes. GDA does not assume any liability arising out of the application or any use of any product or circuit described herein; neither does it convey license under its patent rights or the rights of others.

WARNINGS, CAUTIONS AND NOTES

Warnings identify an operating or maintenance procedure, practice, condition, or statement that, if not strictly followed, could result in death or injury to personnel.

Cautions, which appear elsewhere in this manual, identify an operating or maintenance procedure, practice, condition, or statement that if not strictly followed could result in equipment damage or serious impairment of system operation.

Notes highlight certain operating or maintenance conditions or statements that are essential but not of known hazardous nature as indicated by Warnings and Cautions.

Warnings, Cautions and Notes are included throughout this manual, as required. Additionally, this section contains important Warnings that may not be contained elsewhere within this instruction manual.

- FOR SAFETY REASONS, THE GDA 4022 MUST BE INSTALLED, OPERATED AND SERVICED BY QUALIFIED PERSONNEL ONLY. READ AND UNDERSTAND THIS INSTRUCTION MANUAL COMPLETELY BEFORE OPERATING THE GDA 4022
- THE OPERATION DESCRIBED IN THIS DOCUMENT IS THE INTENDED USE OF THE GDA 4022. GDA CANNOT BE HELD RESPONSIBLE IF THE GDA 4022 IS USED FOR ANY OTHER PURPOSE OTHER THAN THAT STATED. ANY OTHER USE OF THE GDA 4022 WILL RENDER ANY CERTIFICATES ISSUED INAPPLICABLE.

Do **NOT** factory reset controller. A factory reset must only be carried out by a trained technician with appropriate calibration equipment.

Table of Contents

1. Overview:	5
1.1 Overview of Operation	5
1.2 Normal Operation	5
1.3 Alarm Relays	7
1.4 Fault Conditions	7
2 Specifications	8
2.1 General Specification	8
2.2 System Specification	9
2.3 4-20 mA Output Specification	10
3 Installation	11
3.1 Wiring Instructions	11
3.1.1 Power Supply Wiring	11
3.1.2 Relay Wiring	12
3.1.3 Sensor Input Wiring	13
3.1.4 Cable Shield Wiring	14
3.1.5 Analogue Output Wiring	15
4 Setup and Configuration	16
5 Auxiliary Equipment wiring	28

1. Overview:

1.1 Overview of Operation

The 4022 is a two-channel controller accepting 4-20 mA loop powered or 3 wire gas sensors. The 4022 can be used as a two-zone controller with two different gas sensor types or of the same type. The two channels are displayed alternately on an LCD display indicating the gas concentration; and alarms or operational state. The 4022 is field programmable to provide various alarm levels for the relays and analogue outputs. The analogue outputs can be converted to voltage outputs (0-5 VDC or 0-10 VDC) with an external load resistor.

1.2 Normal Operation

In normal operation the display will alternate between two screens every 4 seconds, showing one input per screen. If only one channel is enabled the display will not alternate. The pushbuttons are for menu navigation and have no effect in Normal Operation, only for Setup Mode or a Latched Alarm.

- Screen 1 will display Sensor input 1 gas type and gas concentration detected with its units
- Screen 2 will display Sensor input 2 gas type and gas concentration detected with its units

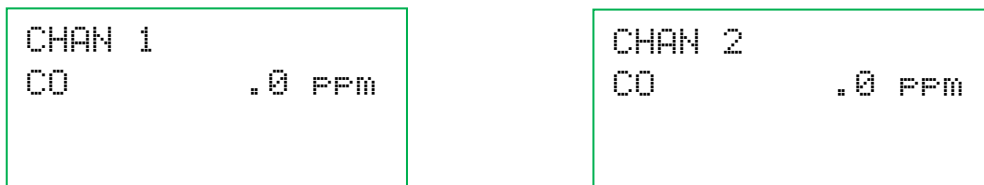
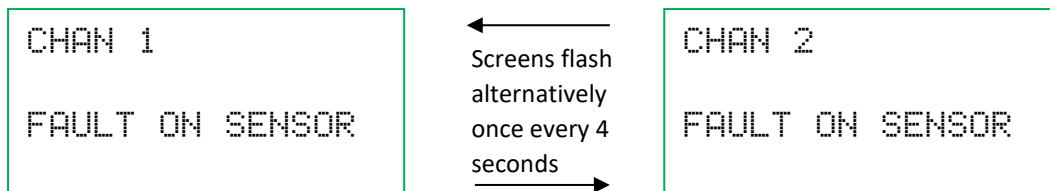
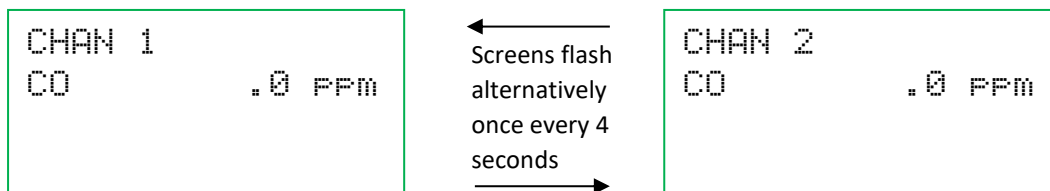

Figure 1: a) Screen 1 display and b) Screen 2 display. (Note CHAN # is the Location Name)

Display in normal operation when sensors are in fault or disconnected. When Input No. 1 and 2 are ON.



Display in normal operation when sensors are connected and operating correctly. When channel 1 and 2 are ON.



In alarm state the display will show the alarming channel for 4 seconds and the other non-alarming channel for 1 second.

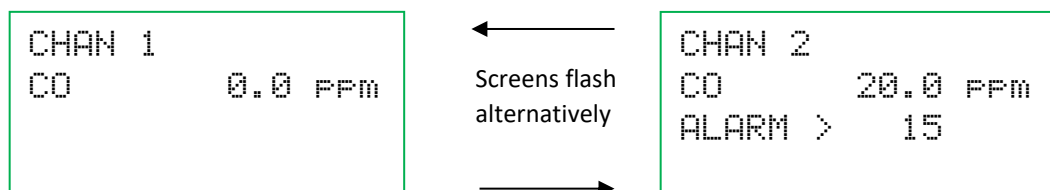

In Alarm Latching Mode the alarm state the display will show only the alarming channel until acknowledge (ACK) is pressed.

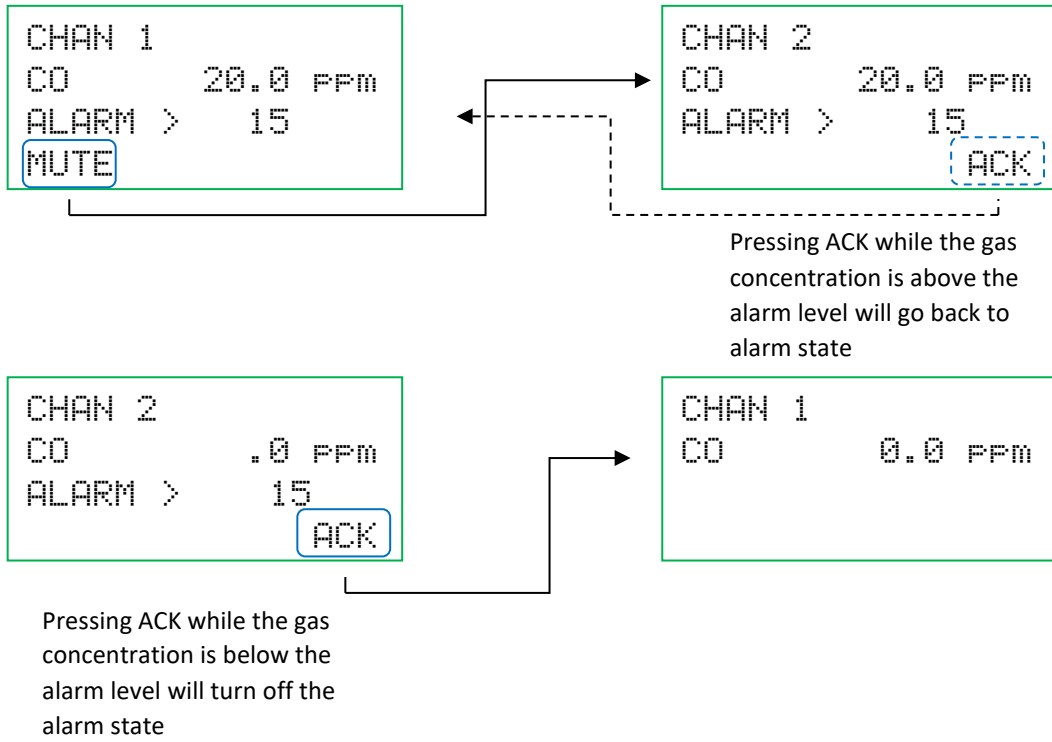

1.3 Alarm Relays

The GDA 4022 has 3 gas alarm level relays for each channel. The alarm level and gas concentration rising or falling are configurable. The alarm relays are not able to be de-energise when in alarm, they will de-energise when the gas concentration has gone below the alarm level. An external Mute Switch is required to mute an external sounder.

DO NOT switch 240 V_{AC} through these relays see the specifications for relay voltages.

When the gas concentration is over the alarm threshold the system will remain in alarm. The gas concentration needs to remain over the alarm threshold for the set **Alarm delay** period (sec) to be recognised as a valid alarm. The **Hysteresis** is an amount that the gas concentration will need to reach below the alarm threshold before the relay will de-energise. The alarm relays will remain on for the set **Relay on time** in minutes after the gas concentration goes below the alarm threshold and hysteresis amount.

```
CHAN 1
CO      17.2 PPM
ALARM > 15
```

Figure 2: Alarm condition display

The Common terminal of the Relays (Alarm and Fault) can be powered by the onboard 24 V_{DC} Output power to save on wiring. This is limited to 2 Amps maximum total current through all relays and Output Power Supply connections. To enable this feature, connect the jumper/shunt onto the appropriate header J5-J11 next to the relay that is desired to be powered.

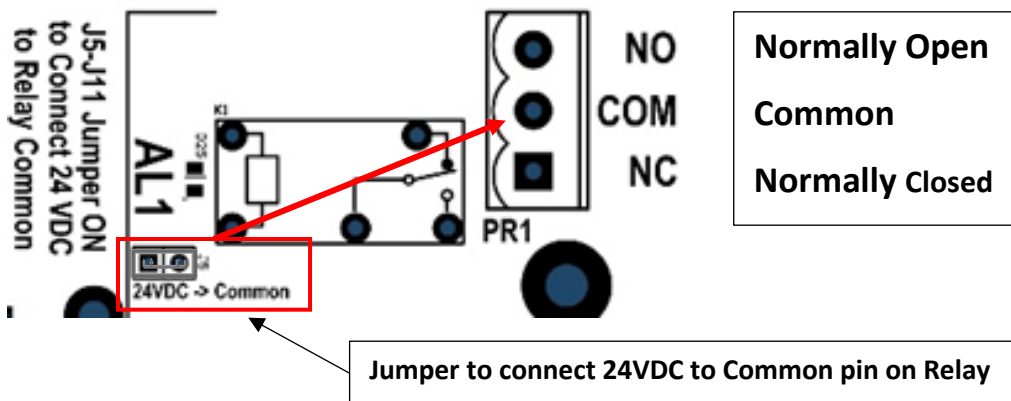

Figure 3: Relay terminal connection and 24 V_{DC} to Common terminal header shown.

1.4 Fault Conditions

When the Fault on Sensor message is displayed on the screen when there is:

- A sensor related fault (<3.0 mA received); or
- The sensor is disconnected/open circuit.

```
CHAN 1
FAULT ON SENSOR
```

```
CHAN 2
FAULT ON SENSOR
```

Figure 4: a) Sensors Fault on channel 1 and b) Sensors Fault on channel 2.

2 Specifications

2.1 General Specification

Table 1: General specifications.

Mains Power Supply Input	100-240 V _{AC} @ 50/60 Hz, ≤ 1.52 A
Mains Power Supply Output	24 V _{DC} ≤ 3.2 A
4022 Input Power	24 V _{DC} (±10 %) ≤ 4.0 A
4022 Output Power	24 V _{DC} (±10 %) ≤ 2.0A
Power Consumption	6.4 W average, excluding sensors, sounder/flashers and attached equipment
Connection Type	4022: Plug-in, Screw-Terminal blocks. PSU: M4 Spade/Fork
Operating Temperature	-10°C to 40°C
Operating Humidity	5% to 95% RH peak noncondensing
Dimensions	400 x 315 x 110 mm (L, W, D)
Enclosure Material	ABS Plastic
IP Rating of Enclosure	IP65 (before user added cable entry), Indoor use only.
Cable Entry	User provided

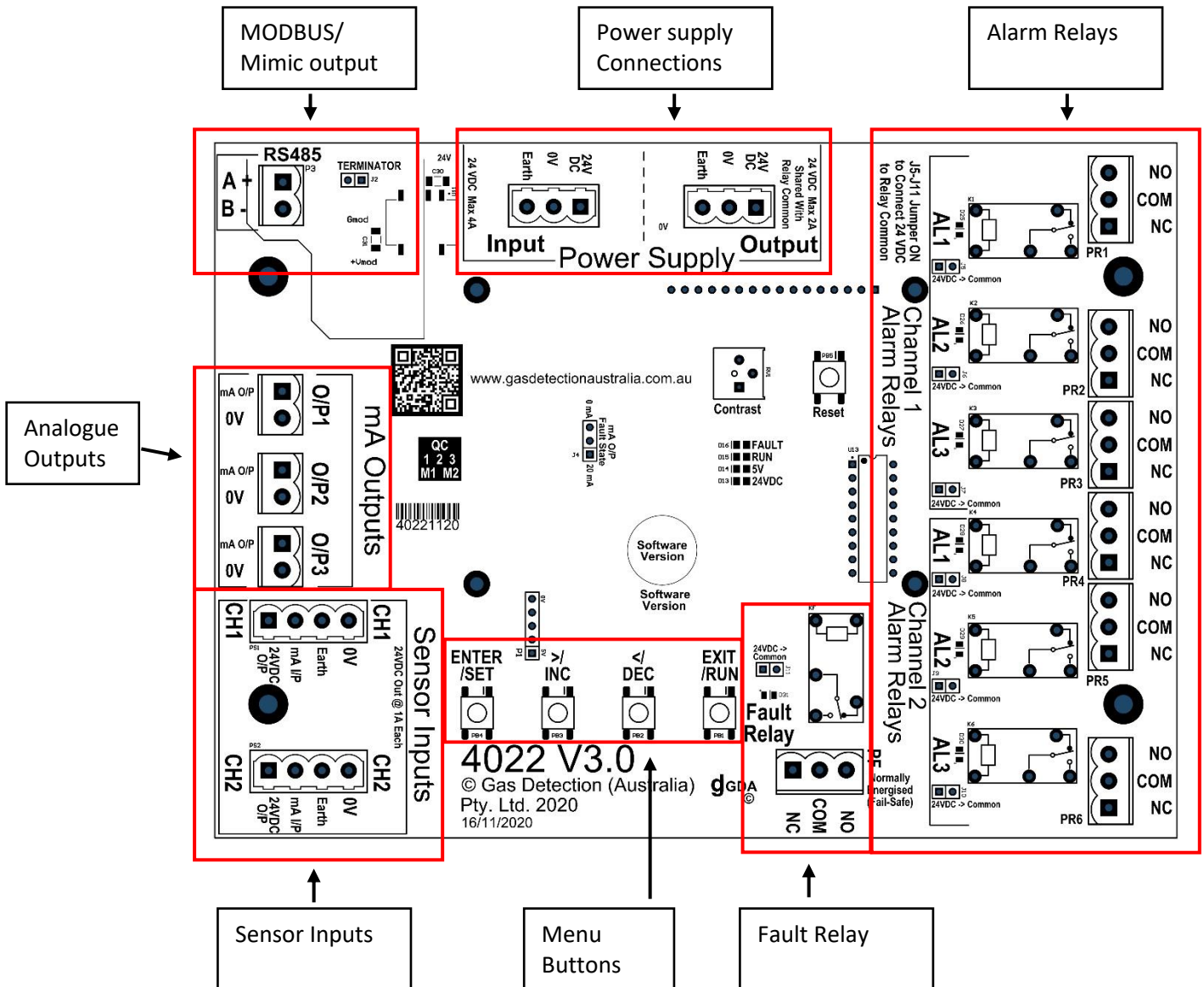

Figure 5: 4022 Main Controller board section identification

2.2 System Specification

Table 2: System specification.

Sensor Inputs	1 to 2 x 4-20 mA sensors (loop powered or 3 wire) Input Resistance: 500 Ω
Display	4x16 (line x character) back lit LCD
Response Time	1 second update rate
Alarm relays	6 x SPDT alarm relays, one for each of the 3 alarm levels, per input.
Analogue Output Type	3 x analogue O/Ps configured as 0-20 mA or 4-20 mA (0-20 mA converted to 0-5 V _{DC} or 0-10 V _{DC} with Resistor)
Relay Specification	SPDT Normally Open 5 A @ 24 V _{DC} Normally Closed 3 A @ 24 V _{DC} Max 30 V _{DC} and Max 24 V _{AC} . Non inductive loads. Volt free or 24 V _{DC} on Common
Fault relay	Fail-Safe (normally energised).
Alarm Relays	3 x SPCO alarm relays per sensor (6x Total) Volt free with 3 contacts available Com, NO, NC
Channel location name	Editable name for each channel up to 13 characters
Gas selection	See Table 8
Units	ppm, % vol. or % LEL
Status	Value or OK (display OK until near alarm level)
Range	1-50000
Alarm level increments	1 ppm, 0.1 % vol. or 0.1 % LEL
Alarm hysteresis	0-50% of sensor range (in selected units)
Alarm hysteresis increments	1 ppm, 0.1 % vol. or 0.1 % LEL
Gas concentration direction	Rising or Falling
Latching alarm	On or Off
Alarm delay	0-600 seconds
Relay on time	0-20 minutes
Analogue outputs	3 x combination of 0-20 mA or 4-20 mA (see section for output options)
Output Update Period	0-10 minutes
Mimic serial Interface	RS485 serial interface to M2001 mimic panel
User interface	4 push button keys (for programming)

2.3 4-20 mA Output Specification

Table 3: Output Modes descriptions.

Output Setup Menu Display	Output Options	Output Description	Notes
Chan Out=In	Output = Sensor Input	Sensor 1 value is output (O/P) on O/P 1 and Sensor 2 value is output on O/P 2. Not available on O/P 3.	
MAX of 1 & 2	None	The highest sensor reading of the two inputs is passed to the O/P	Sensor ranges must be the same.
MIN of 1 & 2	None	The lowest sensor reading of the two inputs is passed to the O/P	Sensor ranges must be the same.
AVERAGE 1 & 2	None	The average sensor reading of the two inputs is passed to the O/P	Sensor ranges must be the same.
SCALED Chan1	Low Level, High Level and Update Period	The O/P is a scaled value of Sensor 1's I/P between two fixed points of the Sensor 1's range.	Sensor ranges must be the same.
SCALED Chan2	Low Level, High Level and Update Period	The O/P is a scaled value of Sensor 2's I/P between two fixed points of the Sensor 2's range.	Sensor ranges must be the same.
SCALED MAX 1 & 2	Low Level, High Level and Update Period	The O/P is a scaled value of the highest sensor I/P between two fixed points of the sensor's range.	Sensor ranges must be the same.
SCALED MIN 1 & 2	Low Level, High Level and Update Period	The O/P is a scaled value of the lowest sensor I/P between two fixed points of the sensor's range.	Sensor ranges must be the same.

Note: The update period is in minutes.

Table 4: Available output modes on each output.

Output MODE	Chan Out = In (Chan 1)	Chan Out = In (Chan 2)	MAX of 1 & 2	MIN of 1 & 2	AVERAGE 1 & 2	SCALED Chan1	SCALED Chan2	SCALED MAX 1 & 2	SCALED MIN 1 & 2
O/P1	YES	NO	YES	YES	YES	YES	YES	YES	YES
O/P2	NO	YES	YES	YES	YES	YES	YES	YES	YES
O/P3	NO	NO	YES	YES	YES	YES	YES	YES	YES

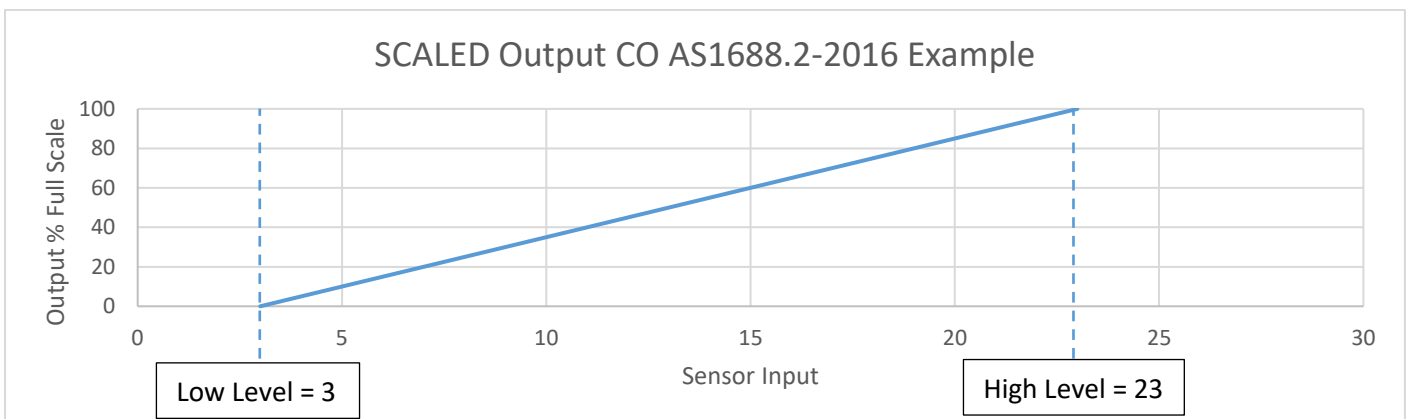

Figure 6: SCALED Output example showing Low Level point and High Level point rescaling the Output to the new range.

3 Installation

1. Locate the mounting holes in the base of the unit. Pay special attention to ensure that swarf or dust does not enter the PCB area.
2. Drill out the required number of cable glands in the box base
3. Fit the gas detection control unit to the wall in the appropriate position. The 4022 can be fixed in any position to allow cable entry top or bottom. It is recommended that the unit be situated away from heavy electrical loads or equipment that emits high levels of EMI or RFI.
4. The sensors must be connected in accordance with drawings in the manual. Check all wiring before connecting mains. All units are configured for 230 V_{AC}, 50 Hz unless marked otherwise on the power supply.
5. The 4022 is factory calibrated and configured to sensors that were sold with it, unless otherwise requested.

3.1 Wiring Instructions

No cable entry is provided at factory to retain the IP rating of the enclosure. Bottom entry conduits or cable glands is recommended. Space around the 4022 main board and next to the power supply allows for wall entry if required. This will reduce the IP rating.

ANY WIRING TO THE POWER SUPPLY MUST BE PERFORMED BY A LICENCED ELECTRICIAN.

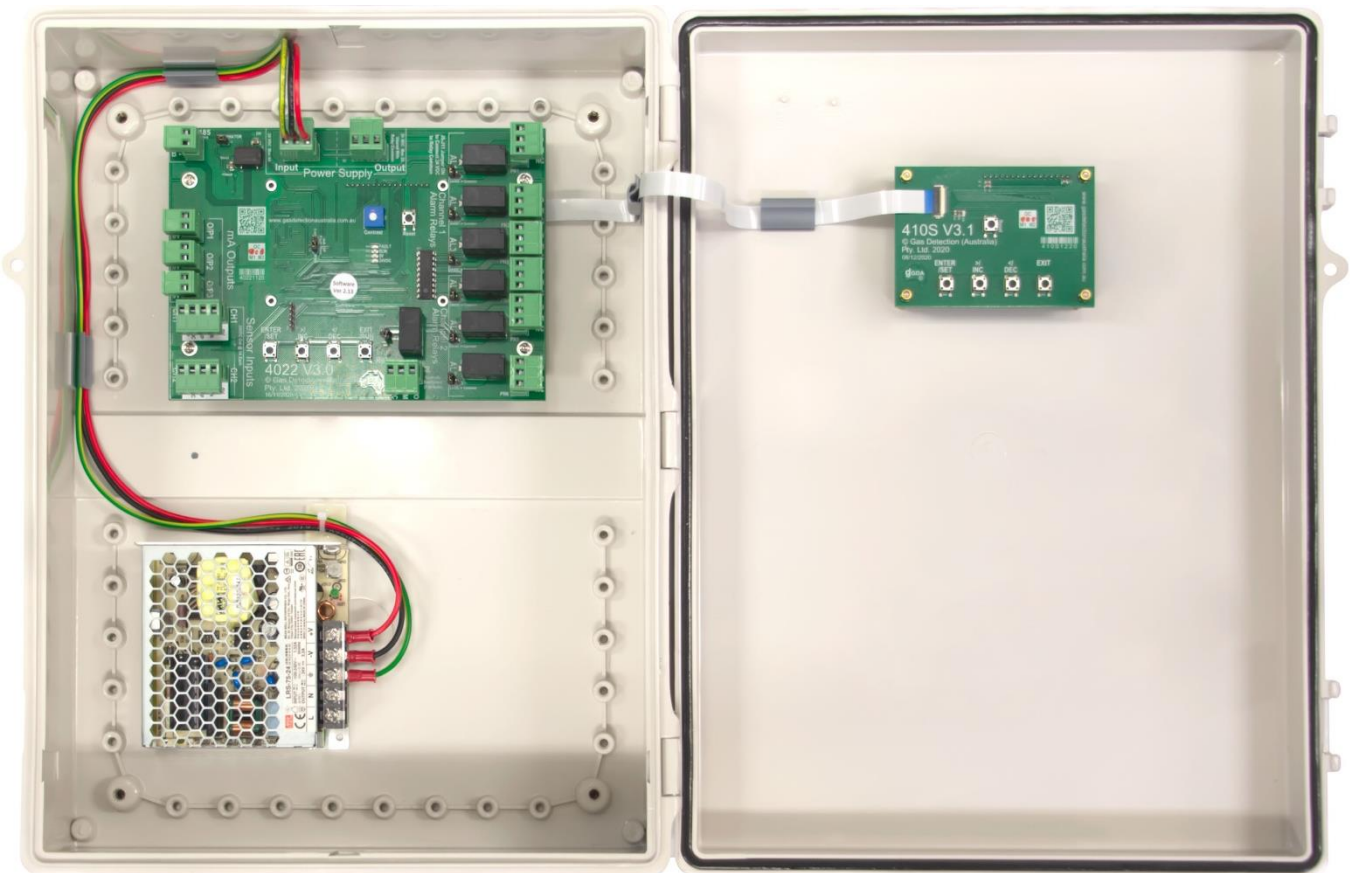
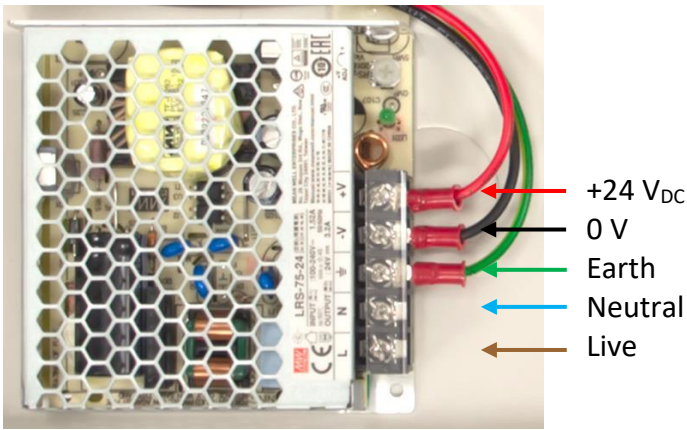

Figure 7: Inside of 4022 enclosure.

3.1.1 Power Supply Wiring

Table 5: Power supply connector descriptions

Connector	PCB Silk	Description
Power Supply (Input)	24 VDC	+24 VDC / Power (+)
	0V	0V,GND / Power (-)
	Earth	Earth
Power Supply (Output)	24 VDC	+24 VDC / Power out (+)
	0V	0V,GND / Power out (-)
	Earth	Earth



ANY WIRING TO THE POWER SUPPLY MUST BE PERFORMED BY A LICENCED ELECTRICIAN.

Figure 8: Power supply terminals.

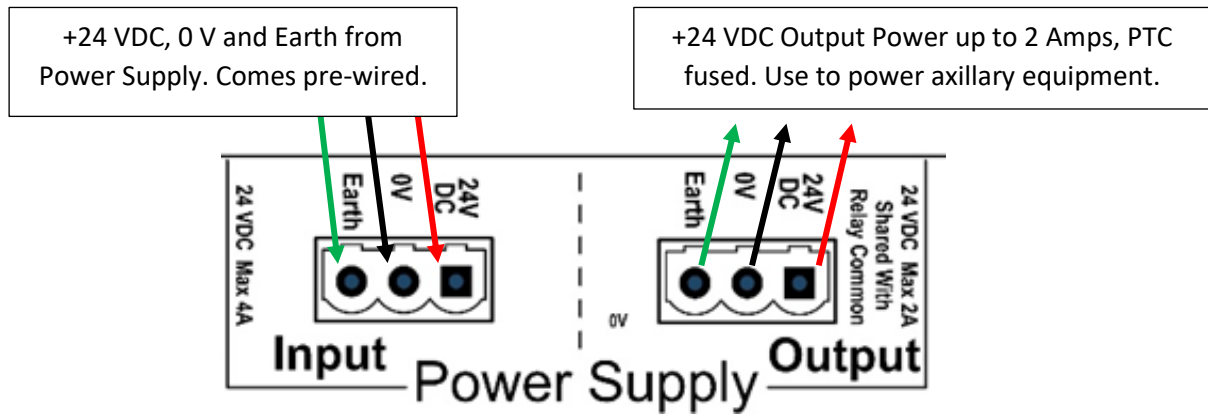

Figure 9: 4022 board power input and axillary power output.

3.1.2 Relay Wiring

As previously shown in **1.3 Alarm Relays** on page 7, the relays can have 24 VDC internally switched onto their respective Common terminals. This feature cuts down wiring when driving auxiliary equipment. Note all power used is shared with the 2 A limit for all relay 24VDC -> Common and the 4022 Power Supply Output connector.

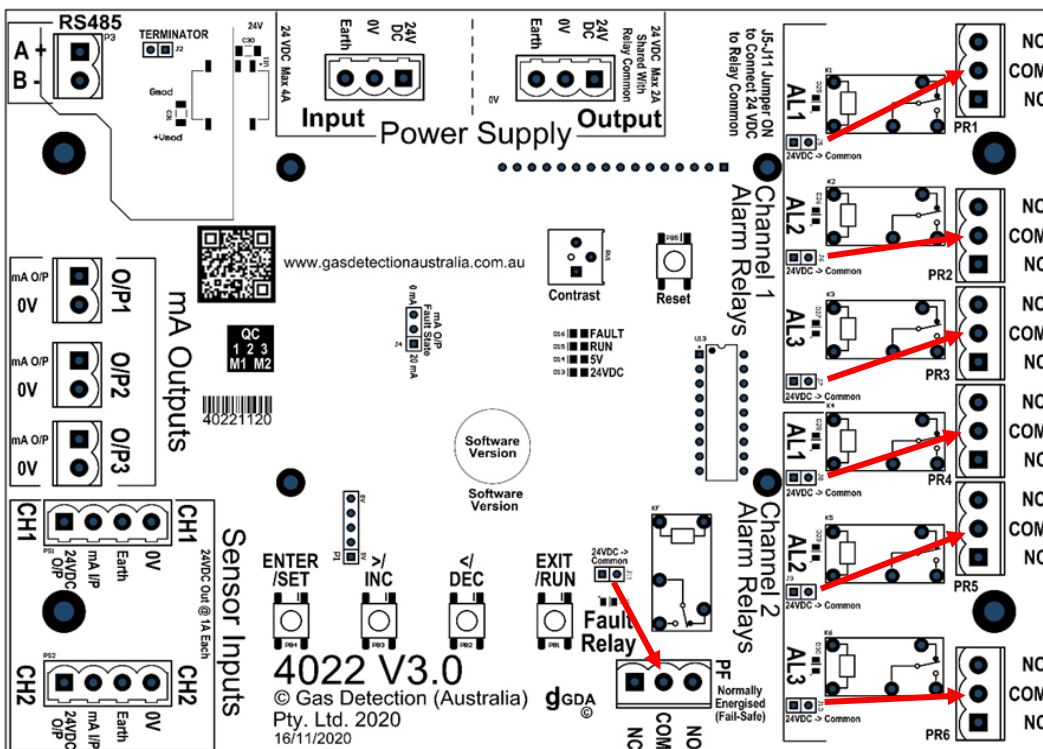

Figure 10: Header (J5-J11) related to the relay Common terminals that they connect 24 VDC to.

3.1.3 Sensor Input Wiring

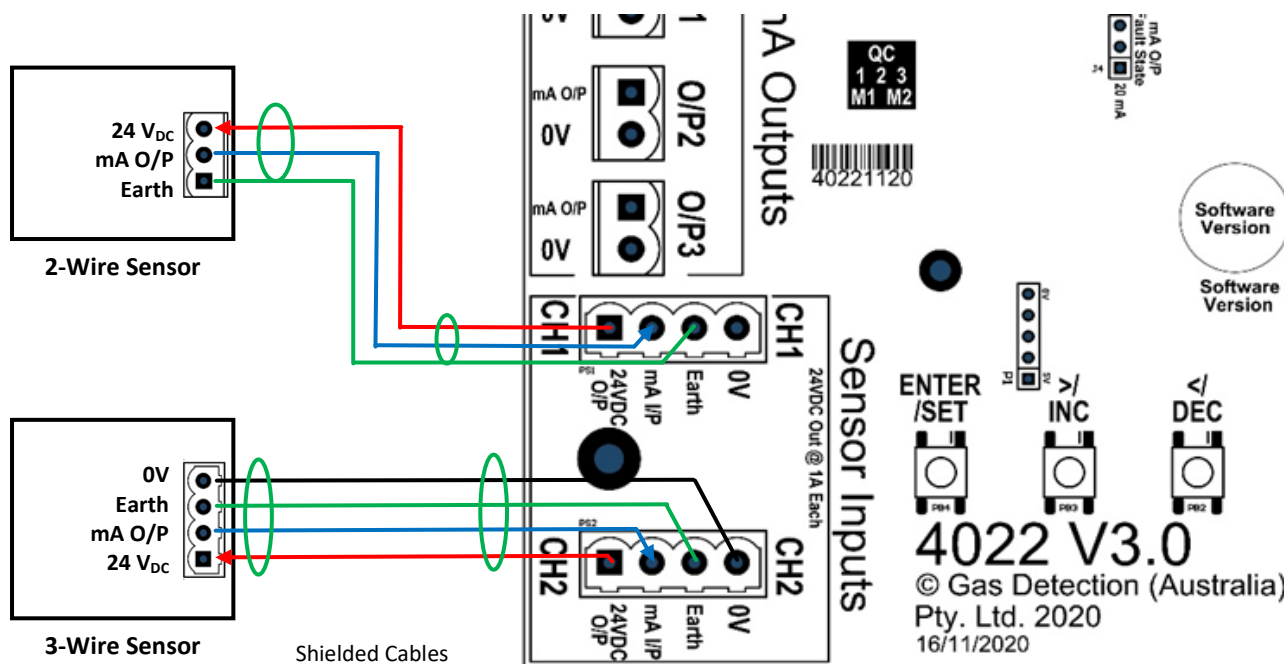

Figure 11: Wiring of 2-wire and 3-wire 4-20 mA sensors to 4022 sensor inputs.

Table 6: Sensor connection description

Sensor type	PCB Silk	Description	Cable Type
4-20 mA Loop Powered	24 VDC O/P	+24V / Power (+)	2 core screened or 3 core cable
	mA I/P	4-20 mA from Sensor	
	Earth	Cable screen/shield	
	0V	-	
4-20 mA Three Wire	24 VDC O/P	+24V / Power (+)	3 core screened or 4 core cable
	mA I/P	4-20 mA from Sensor	
	Earth	Cable screen/shield	
	0V	0V,GND / Power (-)	

3.1.4 Cable Shield Wiring

Shielded cables are required to be used for sensors to reduce RFI and EMI pickup along the cable which may be over 1 km away. Installing unshielded cables will **VOID WARRANTY**. **Figure 11** shows how connect a 2-wire or a 3-wire sensor to the 4022 sensor inputs CH1 and CH2. If the sensor doesn't have an earth terminal, chassis earth or is remotely earthed; still connect the cable shield at the controller and leave it unconnected at the sensor end, see **Figure 12**.

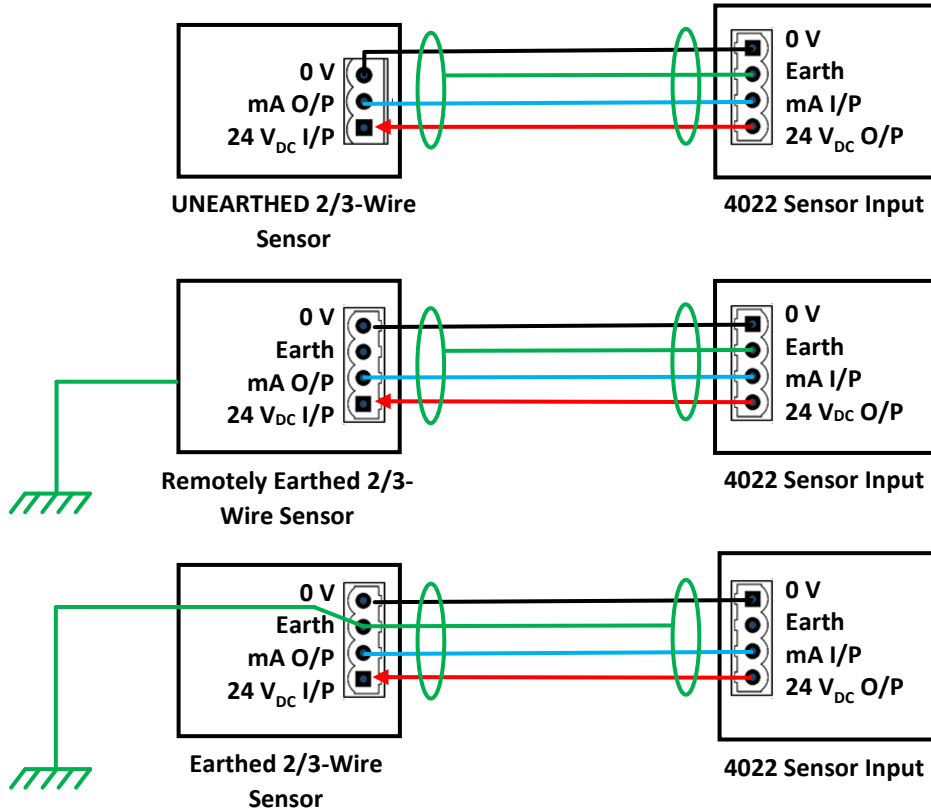

Figure 12: Connecting an a) unearth, b) remotely earth sensor to the 4022 or c) remotely earthed sensor.

DO NOT connect the 4022 Earth to remotely earthed sensor. This will cause an earth loop and inject noise and unknown potentials onto the cable and sensor input.

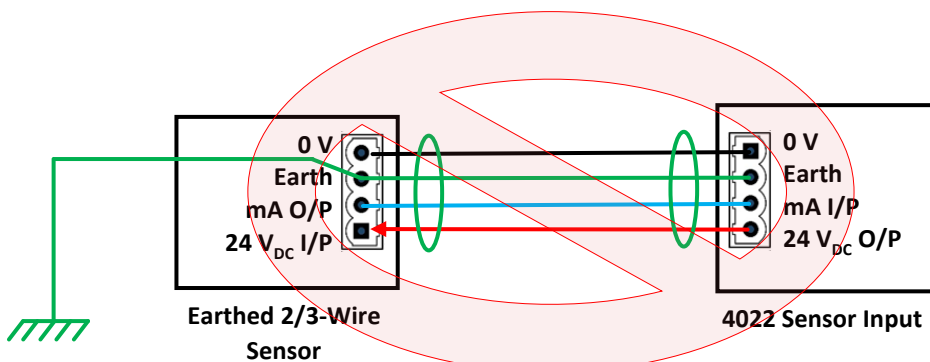

Figure 13: Do not connect remote to 4022 earth connection via cable shield

3.1.5 Analogue Output Wiring

Galvanic isolation of the 0/4-20 mA analogue outputs is **REQUIRED** when driving variable speed drives (VSD) or non-isolated inputs, even if they are operating on the same mains phase. This is due the limited protection provided by the low voltage equipment to handle the industrial noise, voltage spikes, floating grounds and neutral shift voltages. The use of non-isolated 0/4-20 mA analogue outputs with external equipment will **VOID ALL WARRANTIES** of the 4022 and any other connected GDA equipment.

When a voltage output is required the termination resistor **MUST** be fitted at the **EQUIPMENT END** of the line not at the GDA 4022 end, see **Figure 14** for an example of connection to an external 0-10 V_{DC} input. Use **Table 7** to select appropriate resistor for desired voltage output range.

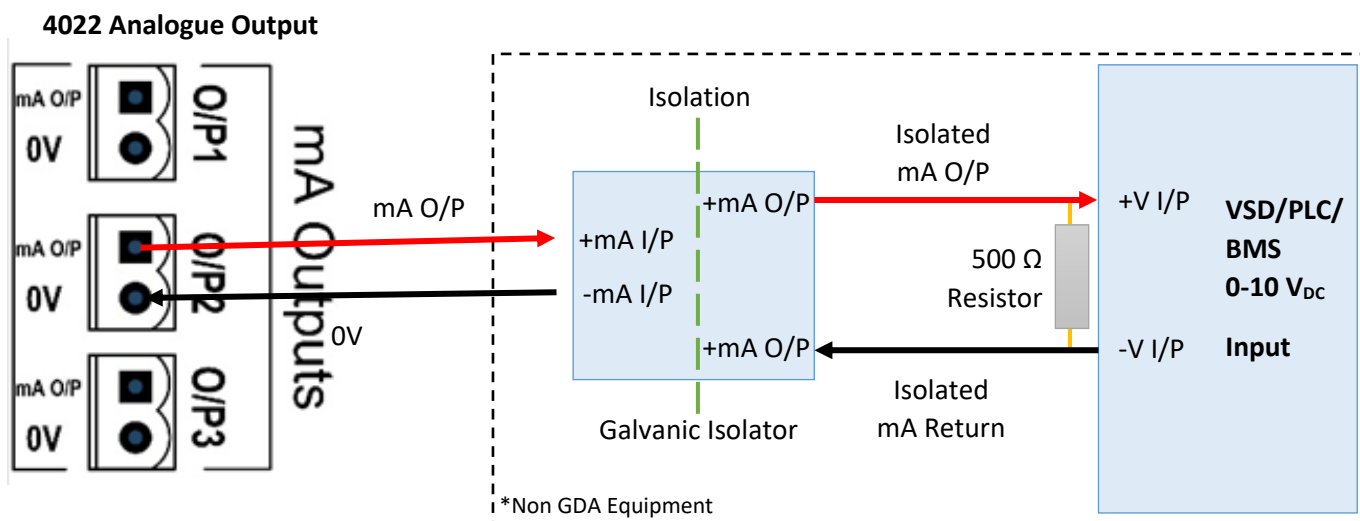

Figure 14: Connection of 4022 analogue output to an external 0-10 V_{DC} input.

Table 7: Resistors for analogue current to voltage conversion.

Resistor (Ω)	“Current Output Mode” 4-20 mA (V)	“Voltage Output Mode” 0-20 mA (V)
100	0.4 – 2	0 – 2
250	1 – 5	0 – 5
500	2 – 10	0 – 10

4 Setup and Configuration

The GDA 4022 can be configured via the internal display and pushbuttons. Most systems are factory set up with the sensors ordered and this section will not have to be followed. The menu system is navigated using the four pushbuttons on the inside of the GDA 4022's front panel. The screen is divided into 4 lines. The bottom line relates to the buttons' function when in setup mode.

To enter Setup hold in the two middle buttons (“</INC” and “>/DEC”) then reset the 4022 either with the Reset pushbutton or by powering up the control board while still holding the two buttons. If left idle in Configuration after 10 minutes the 4022 will return to Normal Operation and any changes will not be saved. The following parameters are programmable by the user:

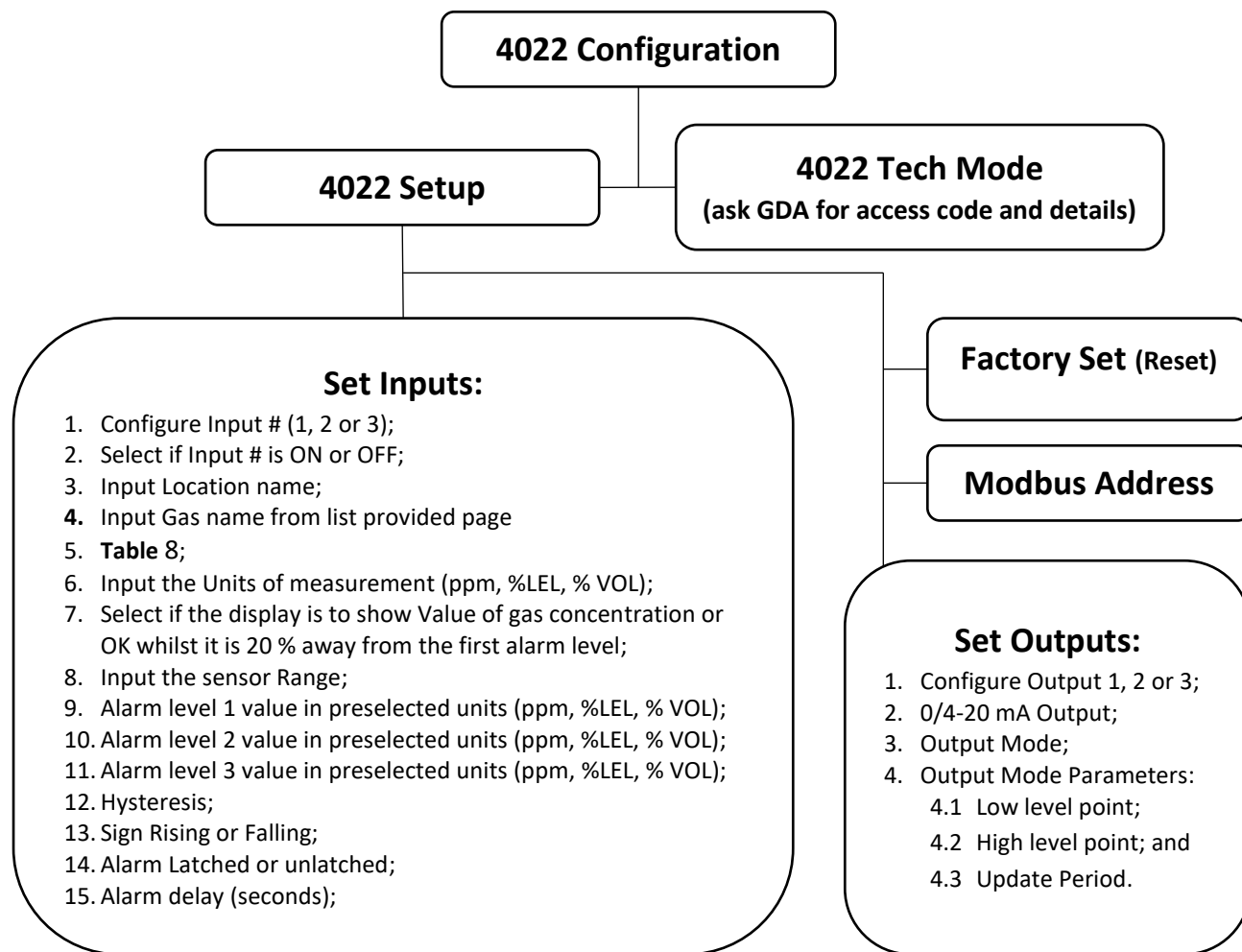

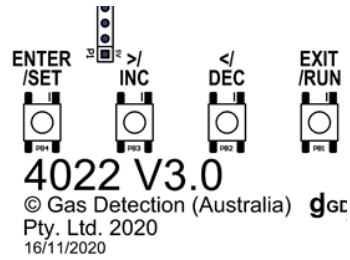
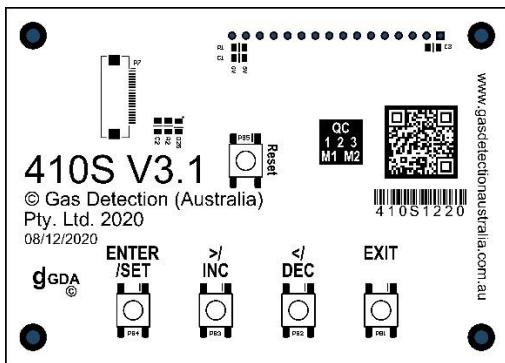

Figure 15: Structure and parameters available in configuration mode.

For purpose of clarity the button to be pressed is marked:  for optional press: 

Use the pushbuttons on the door PCB



Note: Pushbuttons on 4022 PCB are reversed to buttons on screen. Use Buttons on 410S PCB.

Figure 16: a) 410S V3.1 electronics on inside of door and b) pushbuttons on 4022 board.

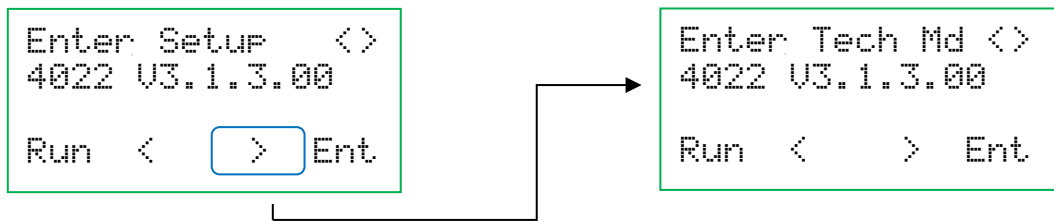

To Configure Sensor Inputs.

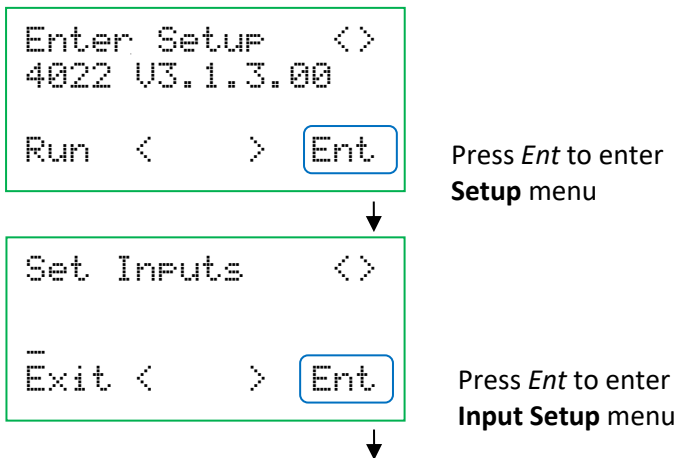

Enter **Set Inputs** to change all the sensor information required along with the alarm relay information.

Select Channel Number

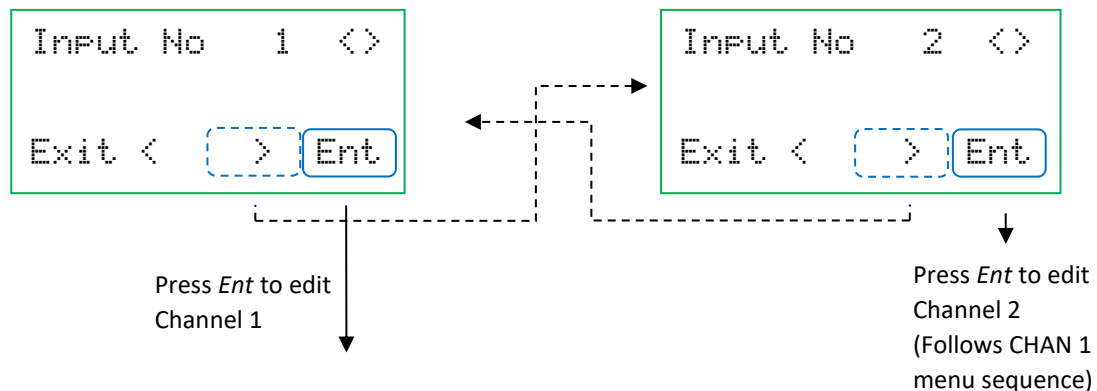

Select Channel On/Off

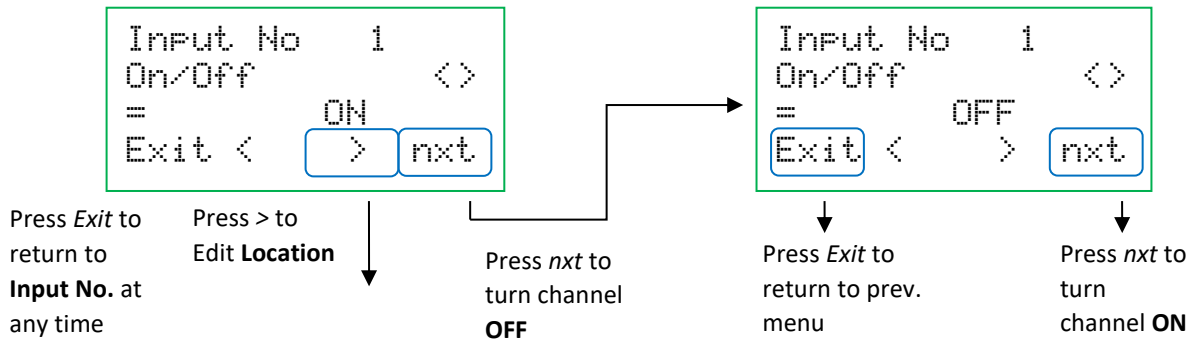

Edit Location Name

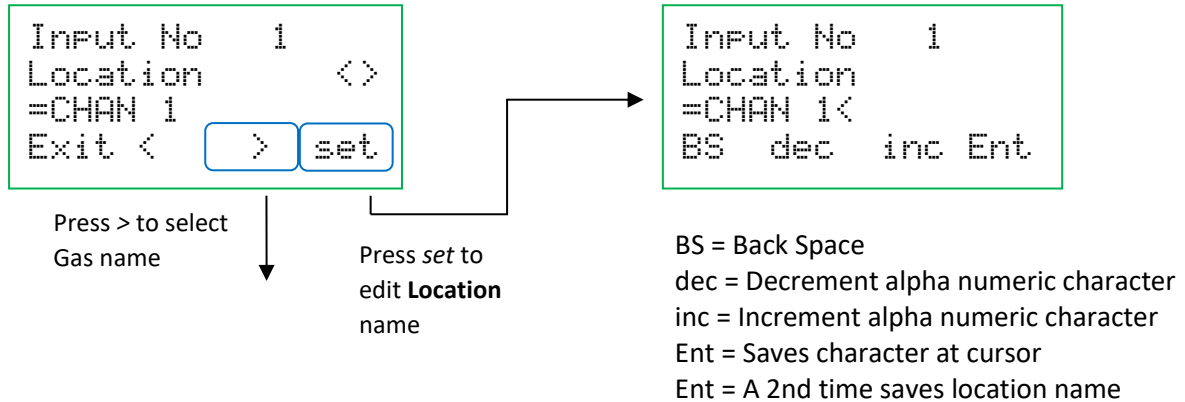

Select Gas Name

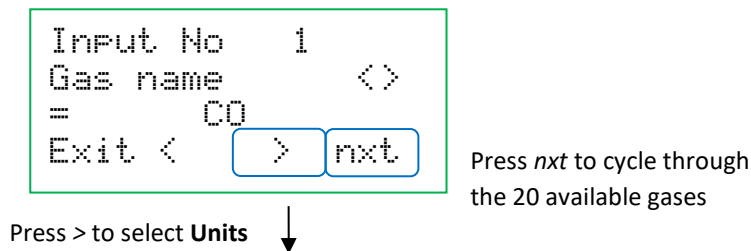
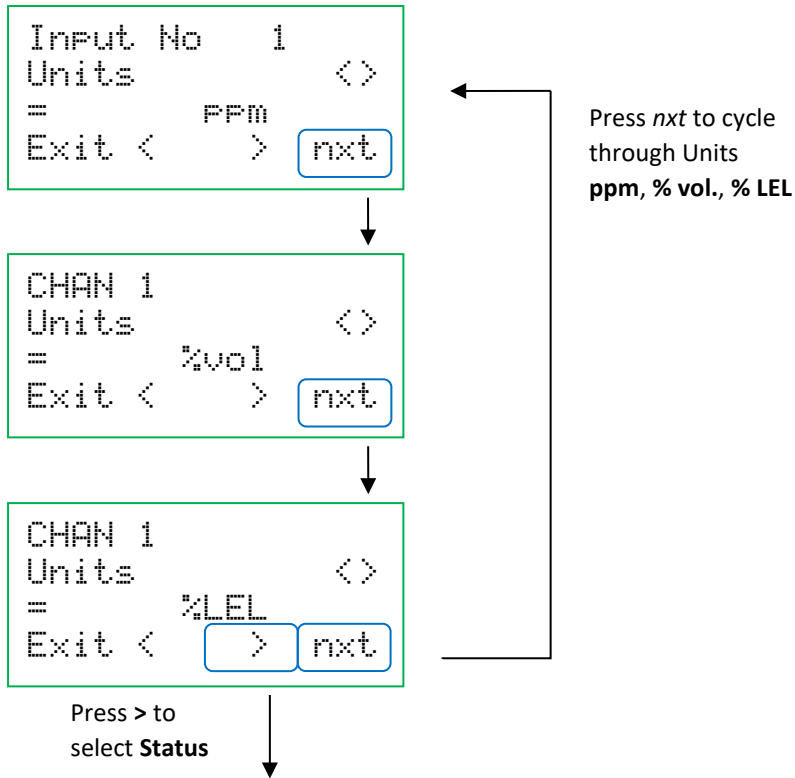

Table 8: Available gas list

Selectable Gases	Gas Name	Chemical Formula
CO	Carbon monoxide	CO
O2	Oxygen	O ₂
CO2	Carbon dioxide	CO ₂
FLM	Flammable	
H2	Hydrogen	H ₂
CH4	Methane	CH ₄
LNG	Liquefied Natural Gas	CH ₄
Prop	Propane	C ₃ H ₈
LPG	Liquefied Petroleum Gas	C ₃ H ₈
H2S	Hydrogen sulphide	H ₂ S
NH3	Ammonia	NH ₃
NO2	Nitrogen dioxide	NO ₂
Gas	Gas	
R22	R22 Refrigerant	
R123	R123 Refrigerant	
R134a	R134a Refrigerant	
R407c	R407c Refrigerant	
R410a	R410a Refrigerant	
Refrg	Refrigerant	
	Blank field for unique gas	

Select Units of Measurement



Select Status

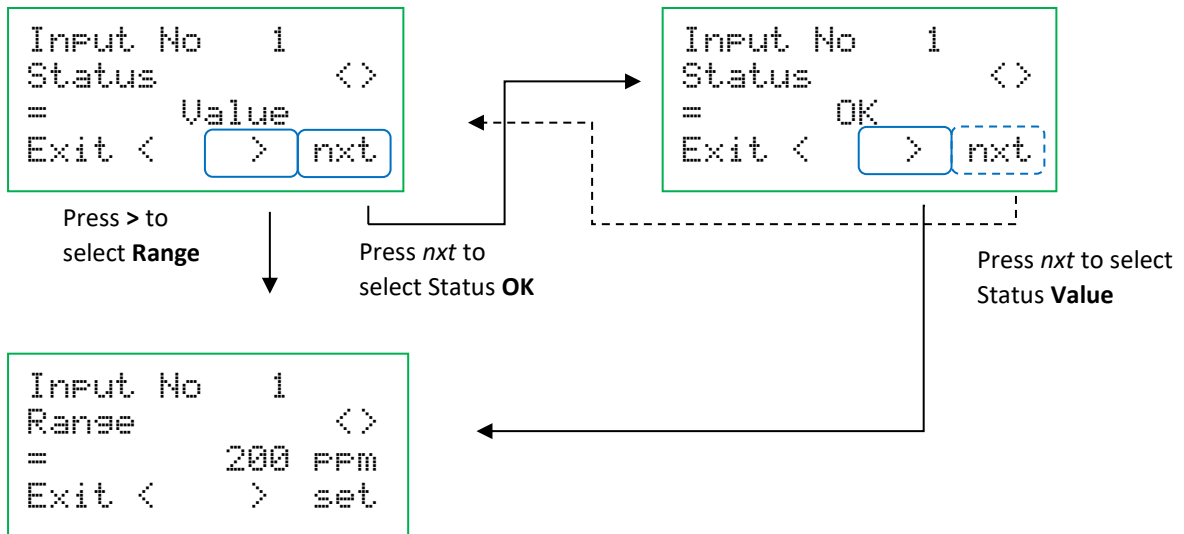

Edit Range

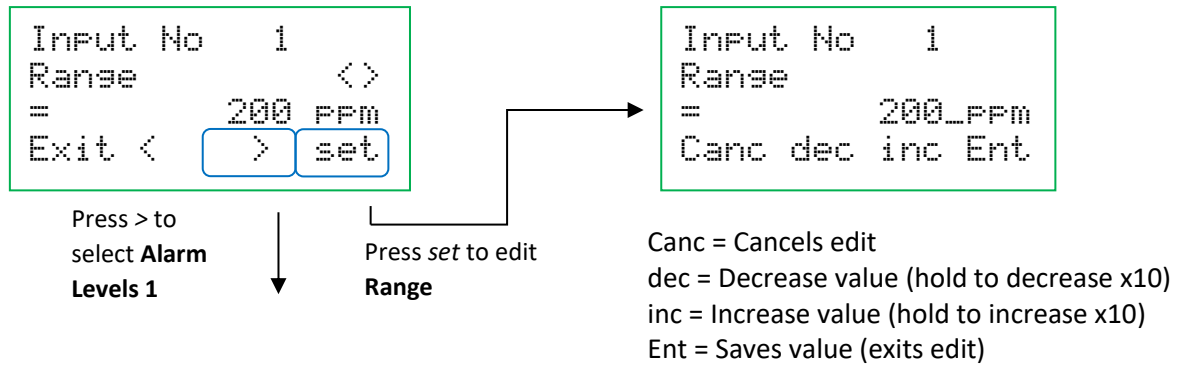

Edit Alarm Levels

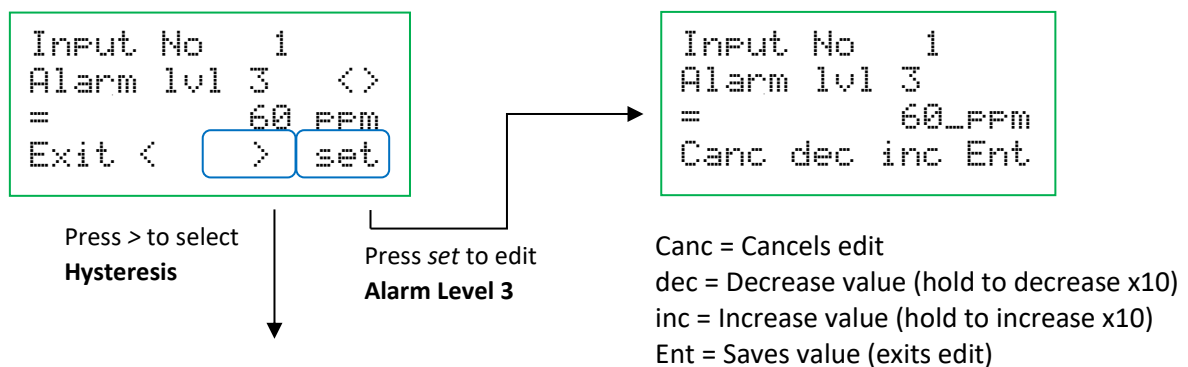
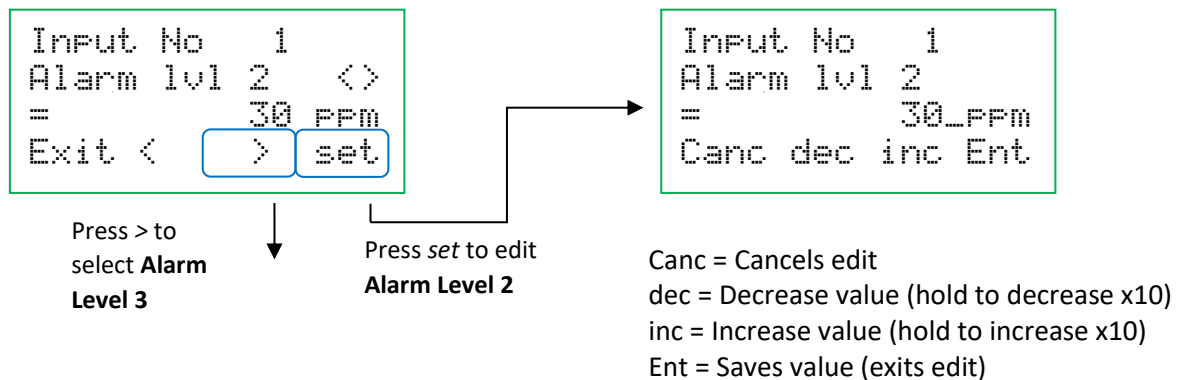
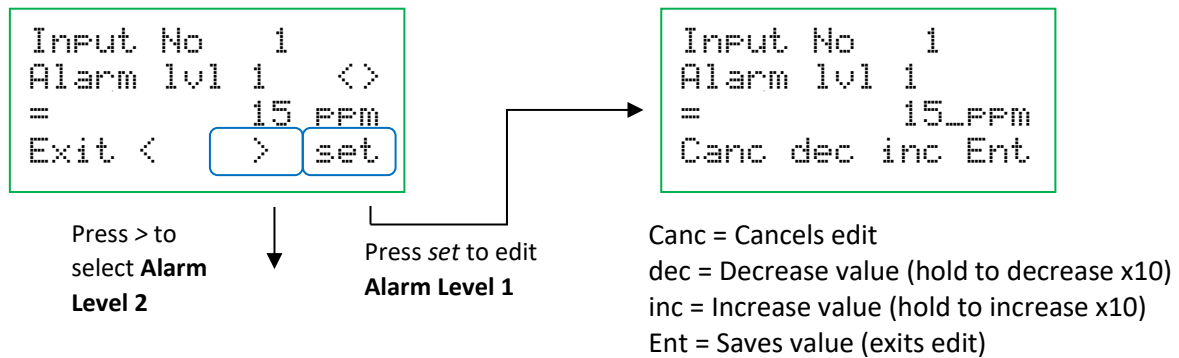

Edit Hysteresis

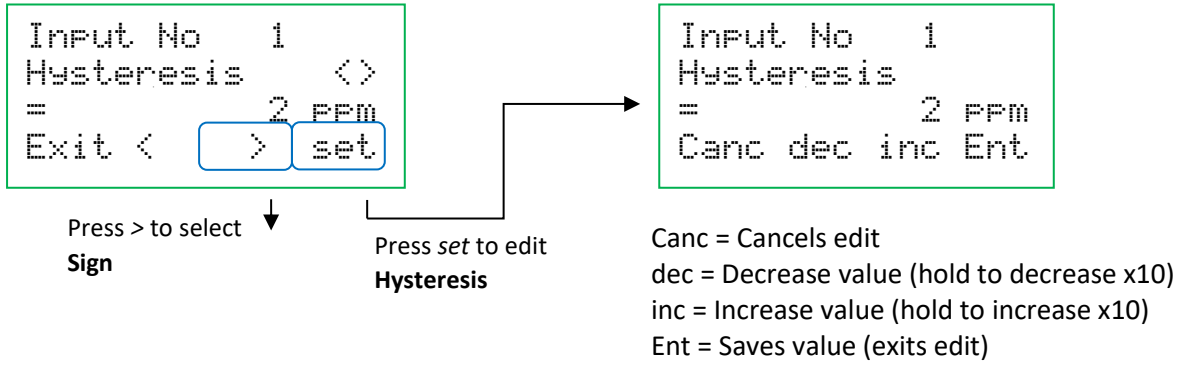

Select Sign

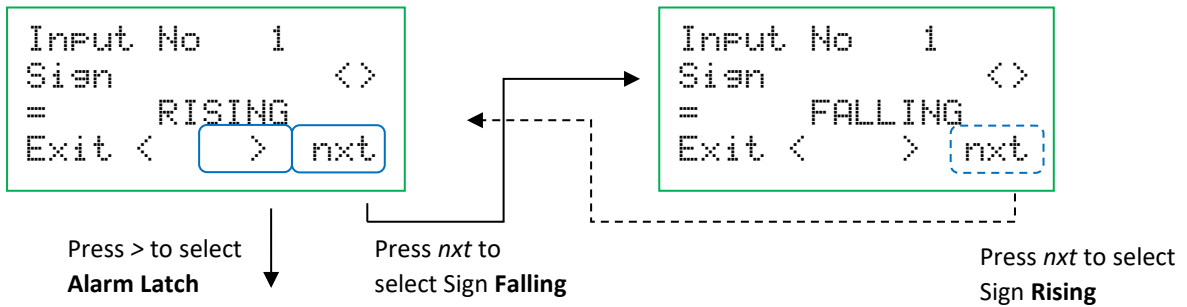

Alarm Latch

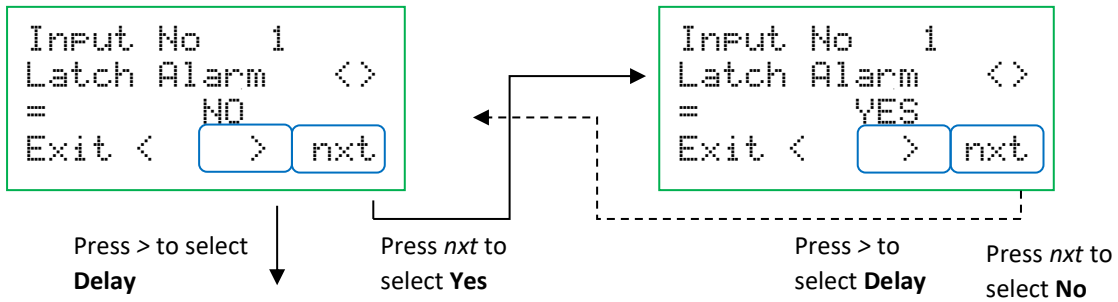

Edit Alarm Delay

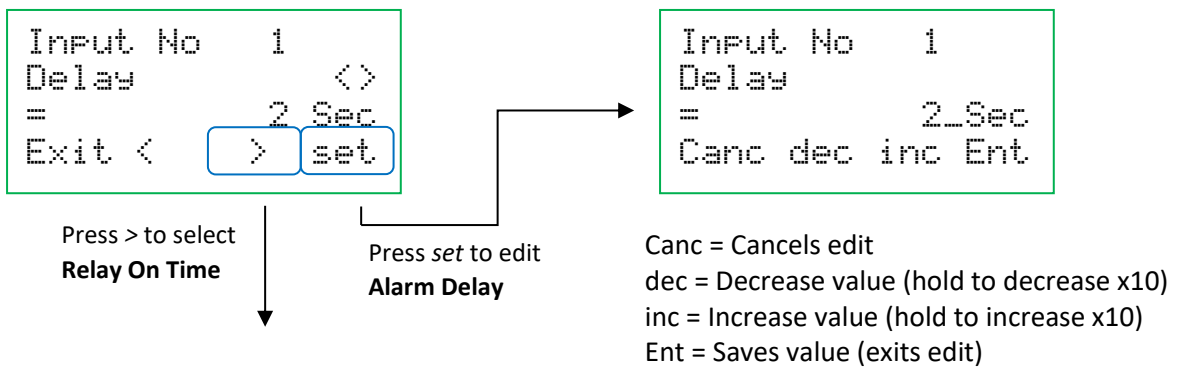

Alarm Relay On Time

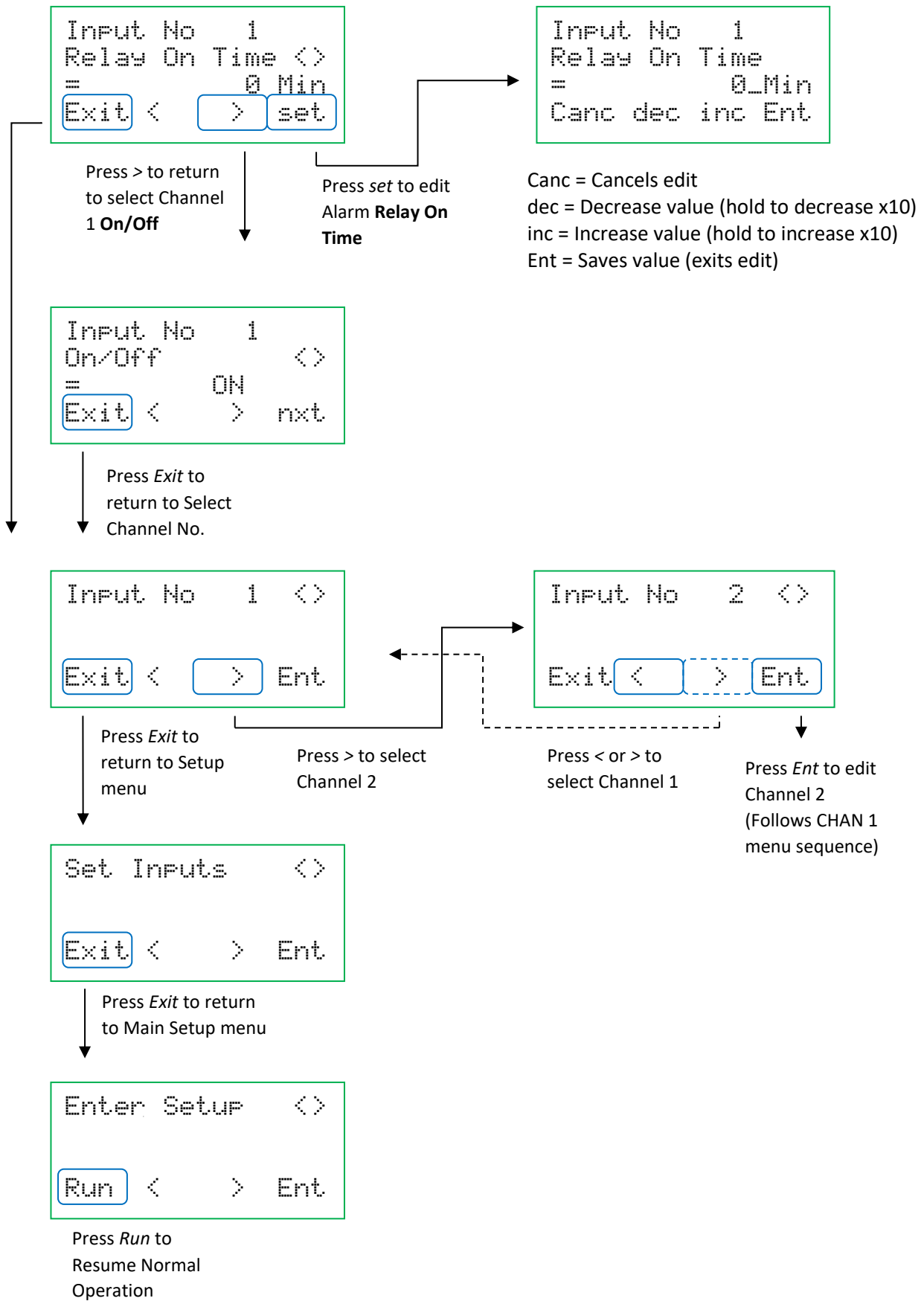

Setting up of analogue outputs

(4-20mA; 0- 20mA; 0-5VDC; 0-10VDC)

The analogue outputs can be used to drive ancillary equipment such as VSD inputs or inputs into other BMS systems.

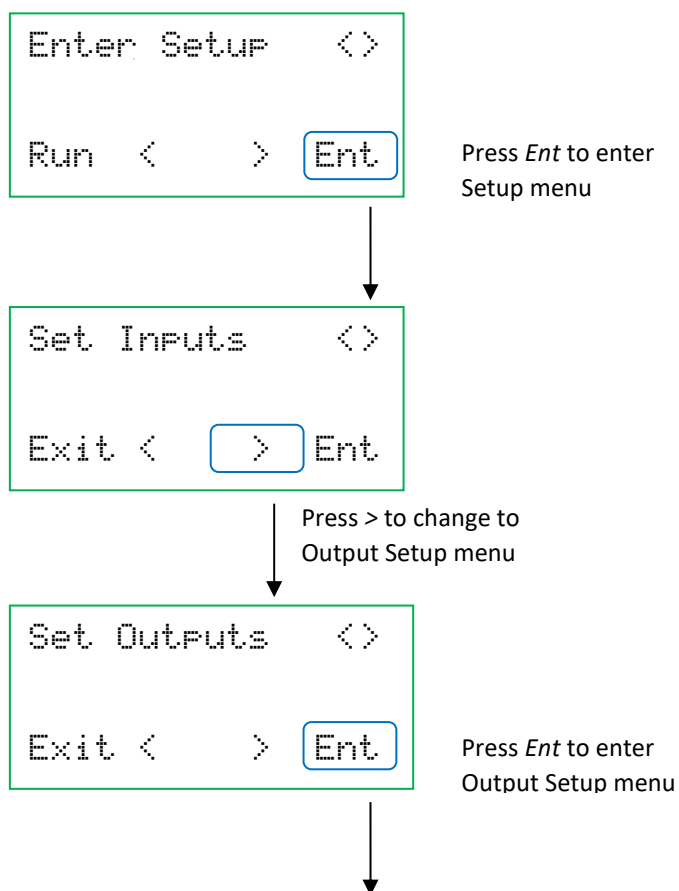

Select Output 1, 2 or 3

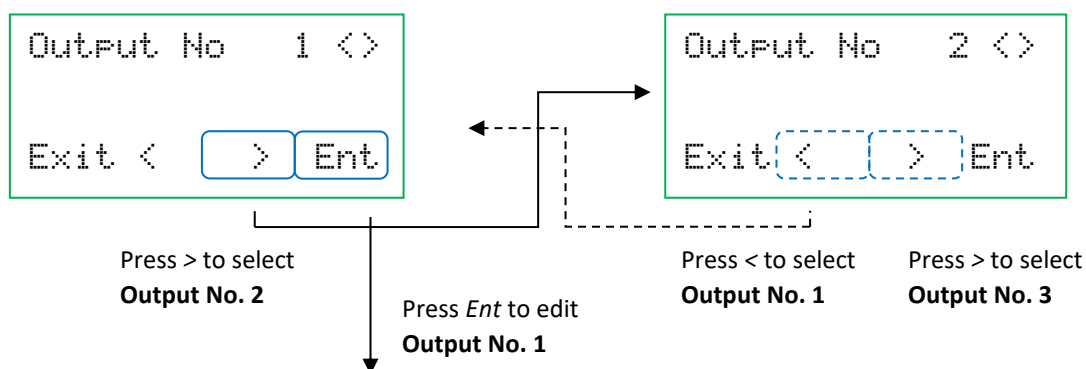

Select Output Type: Current or Voltage

If 0-10 VDC is used a 500 Ohm resistor must be connected across the output pins.

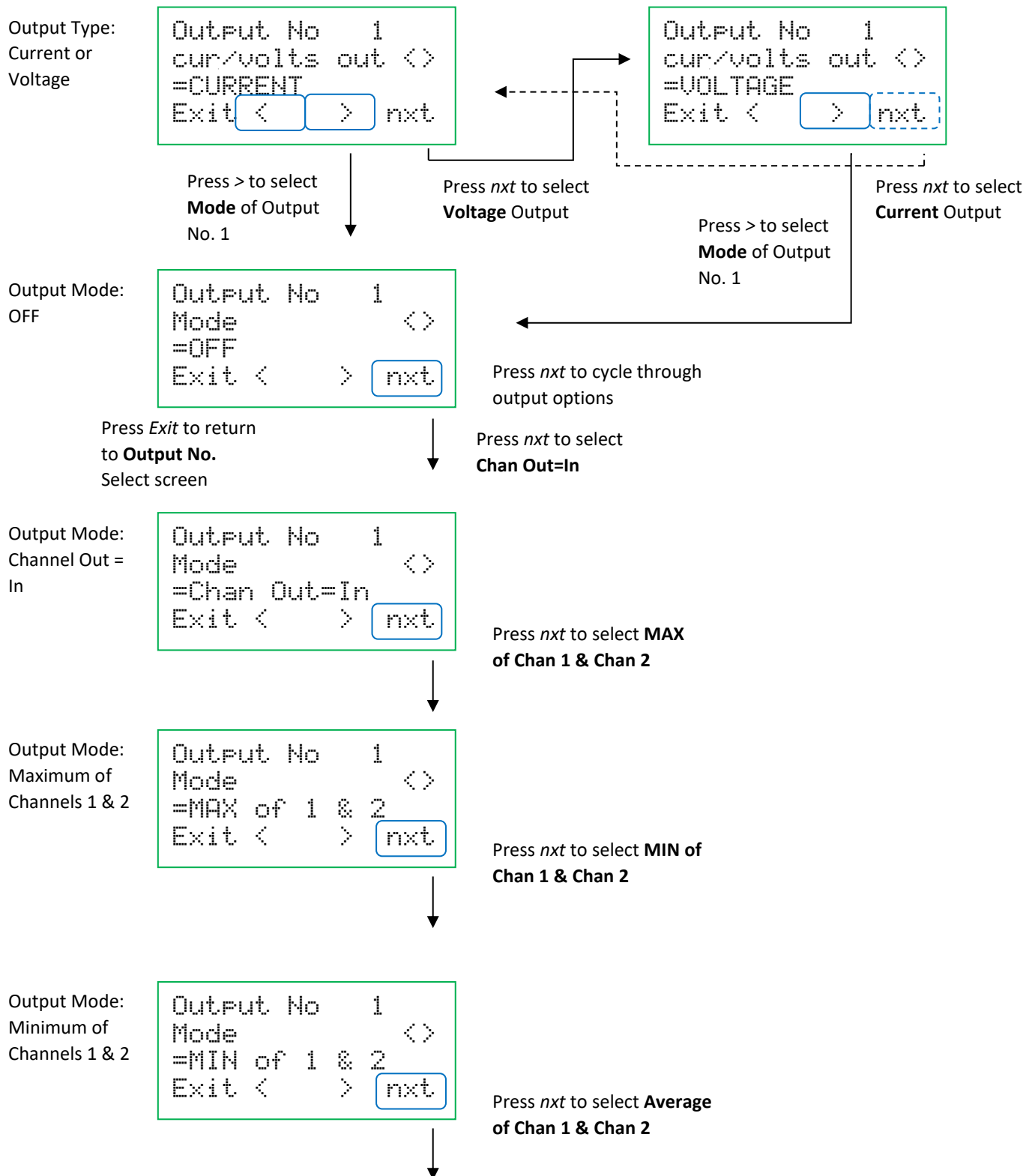

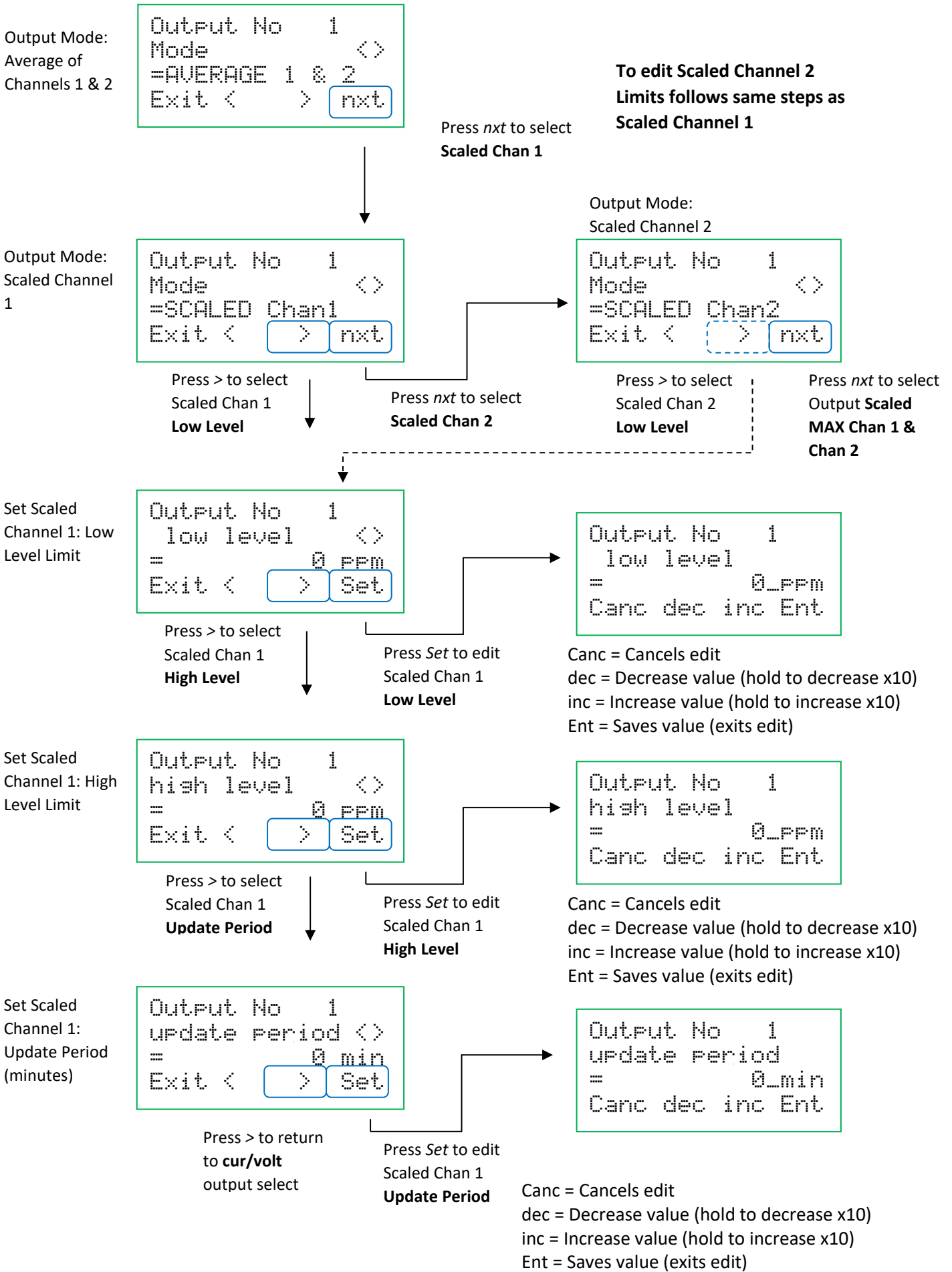

Output Mode:
Scaled
Maximum of
Channels 1 & 2

```
Output No 1
Mode      <>
=SCALED MAX1&2
Exit < [ ] > [nxt]
```

Press > to select
Scaled MAX
Chan 1 & Chan 2
Low Level

Press *nxt* to select
Scaled **MIN** Chan 1
& Chan 2

**To edit Scaled MIN1&2
Limits follows same steps as
Scaled MAX1&2**

```
Output No 1
Mode      <>
=SCALED MIN1&2
Exit < [ ] > [nxt]
```

Press > to select
Scaled MIN Chan
1 & Chan 2 **Low**
Level

Press *nxt* to
select Output
OFF

Set Scaled
Maximum of
Channels 1 & 2:
Low Level Limit

```
Output No 1
low level <>
=          0 PPM
Exit < [ ] > [Set]
```

Press > to select
Scaled MAX
Chan 1 & Chan 2
High Level

Press *Set* to edit
Scaled MAX Chan 1
& Chan 2 **Low Level**

```
Output No 1
low level
=          0_PPM
Canc dec inc Ent
```

Canc = Cancels edit
dec = Decrease value (hold to decrease x10)
inc = Increase value (hold to increase x10)
Ent = Saves value (exits edit)

Set Scaled
Maximum of
Channels 1 & 2
High Level Limit

```
Output No 1
high level <>
=          0 PPM
Exit < [ ] > [Set]
```

Press > to select
Scaled MAX
Chan 1 & Chan 2
Update Period

Press *Set* to edit
Scaled MAX Chan 1
& Chan 2 **High Level**

```
Output No 1
high level
=          0_PPM
Canc dec inc Ent
```

Canc = Cancels edit
dec = Decrease value (hold to decrease x10)
inc = Increase value (hold to increase x10)
Ent = Saves value (exits edit)

Set Scaled
Maximum of
Channels 1 & 2:
Update Period

```
Output No 1
update period <>
=          0 min
Exit < [ ] > [Set]
```

Press > to return
to **cur/volt**
output select

Press *Set* to edit
Scaled MAX Chan 1
& Chan 2 **Update
Period**

```
Output No 1
update period
=          0_min
Canc dec inc Ent
```

Canc = Cancels edit
dec = Decrease value (hold to decrease x10)
inc = Increase value (hold to increase x10)
Ent = Saves value (exits edit)

Please note the various Output Modes may only be connected to the Outputs shown in Table 4.

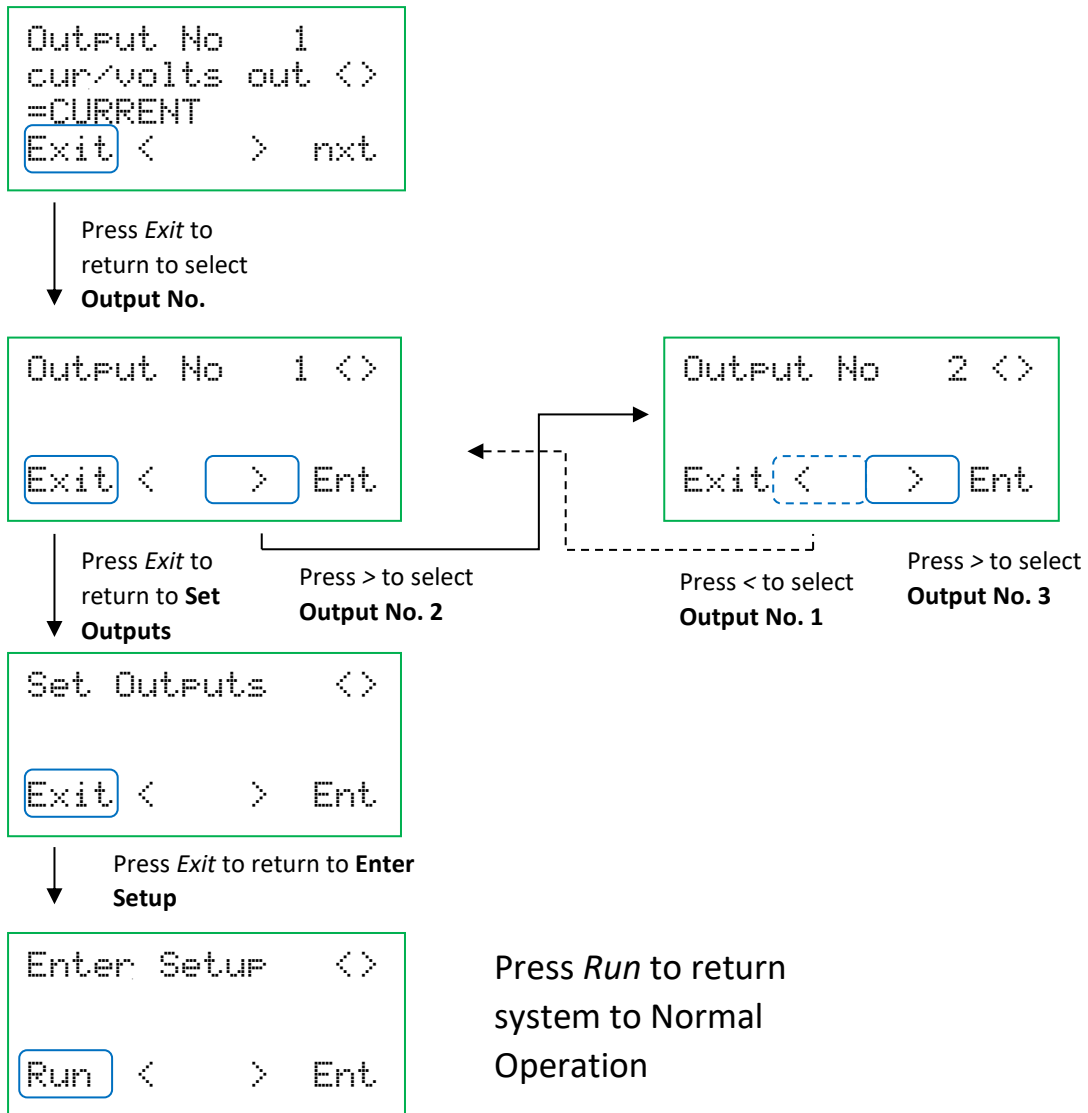

5 Auxiliary Equipment Wiring

Recommended example of wiring the 4022 alarm relays. This example shows the wiring of both channel alarm 1's to a single 24 VDC signal and both channel alarm 2's and the fault to a single 24 VDC signal.

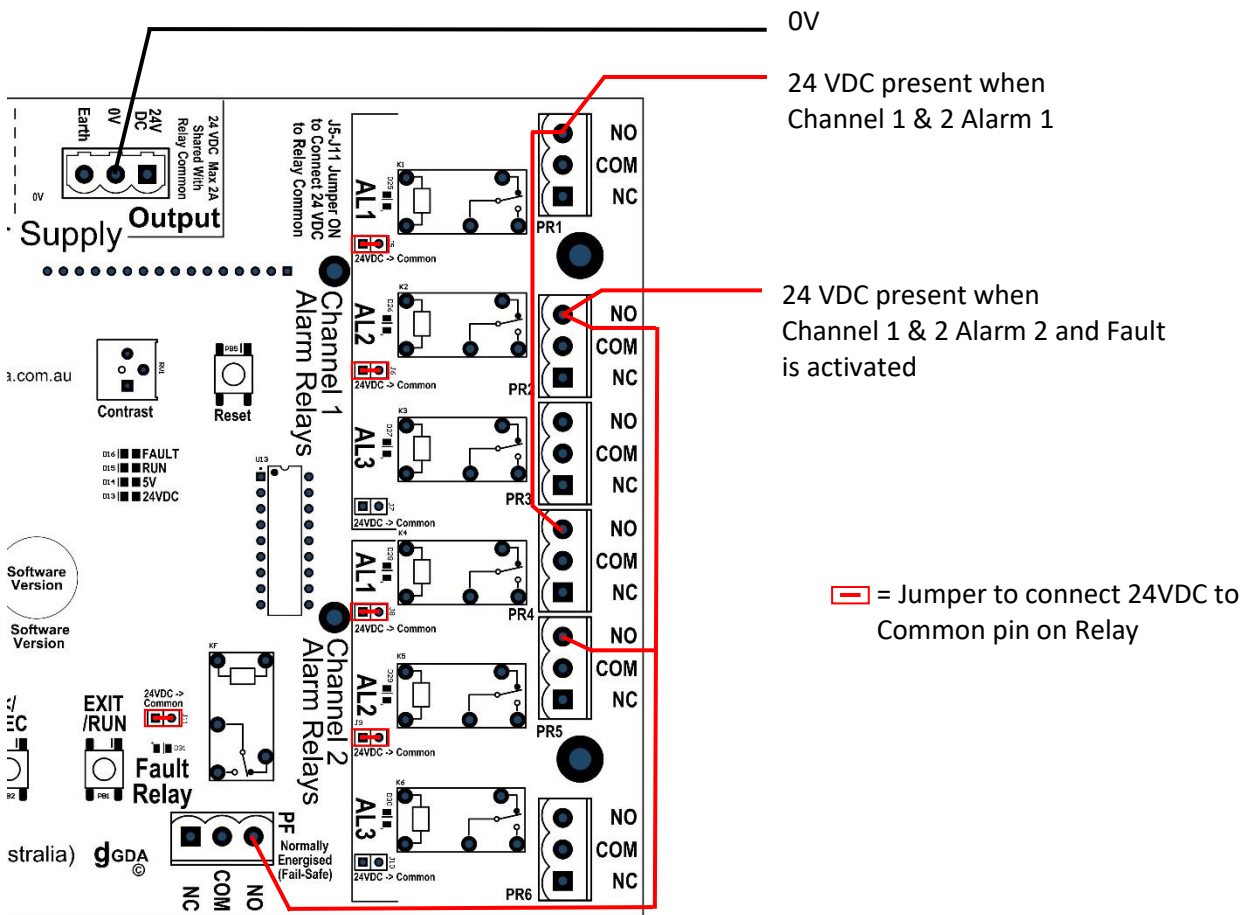

Figure 17: The above example of wiring the 4022 alarm relays using the Jumper J5-J11 to power the commons of the relays.

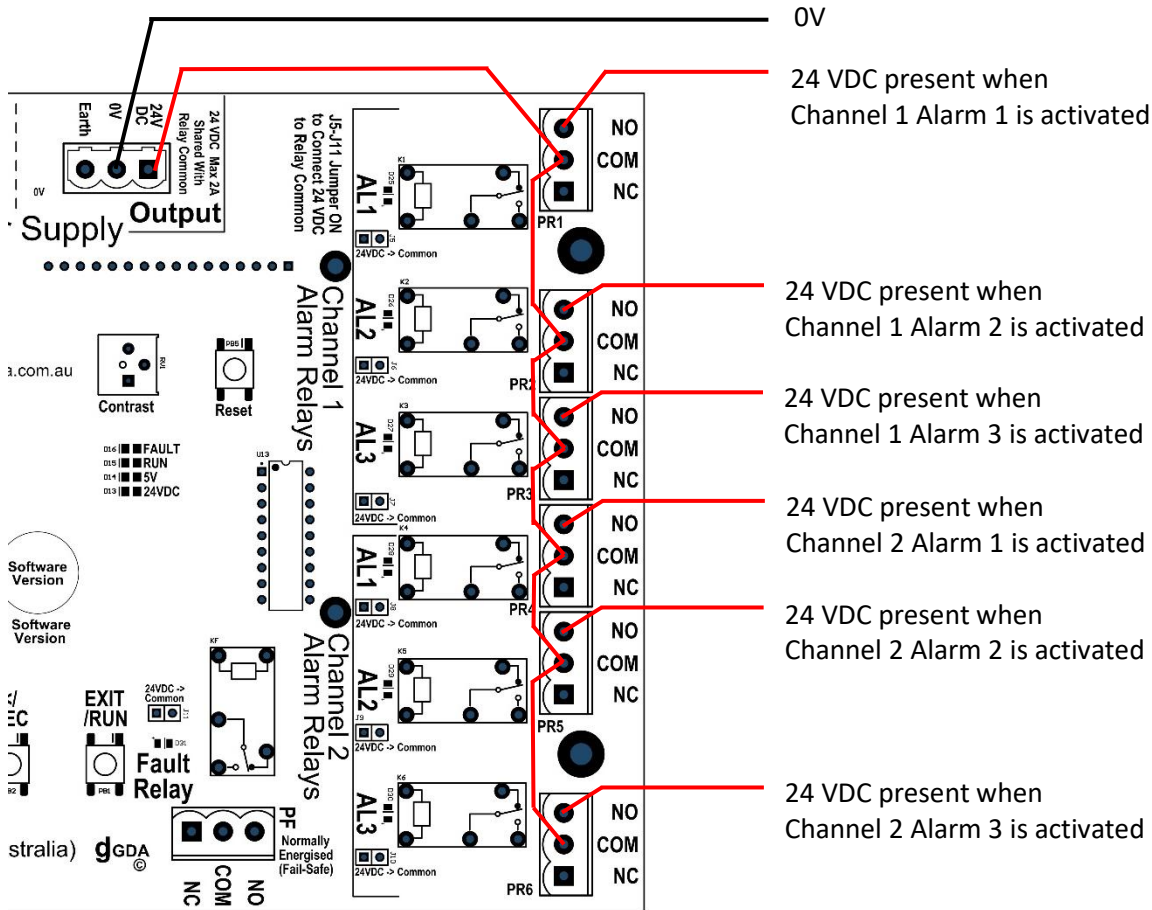

Figure 18: The above example of wiring the 4022 alarm relays using the power supply output (24 VDC) to power the commons of the relays.

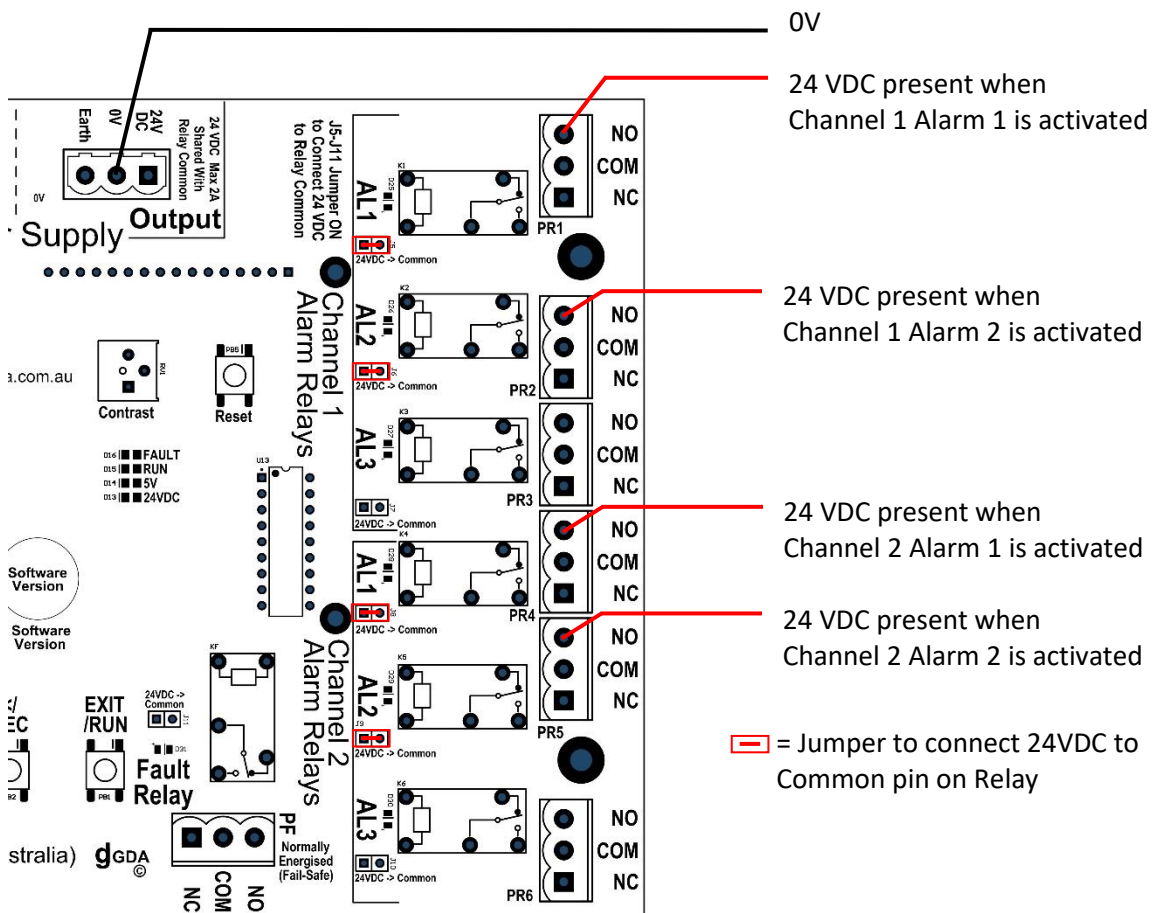
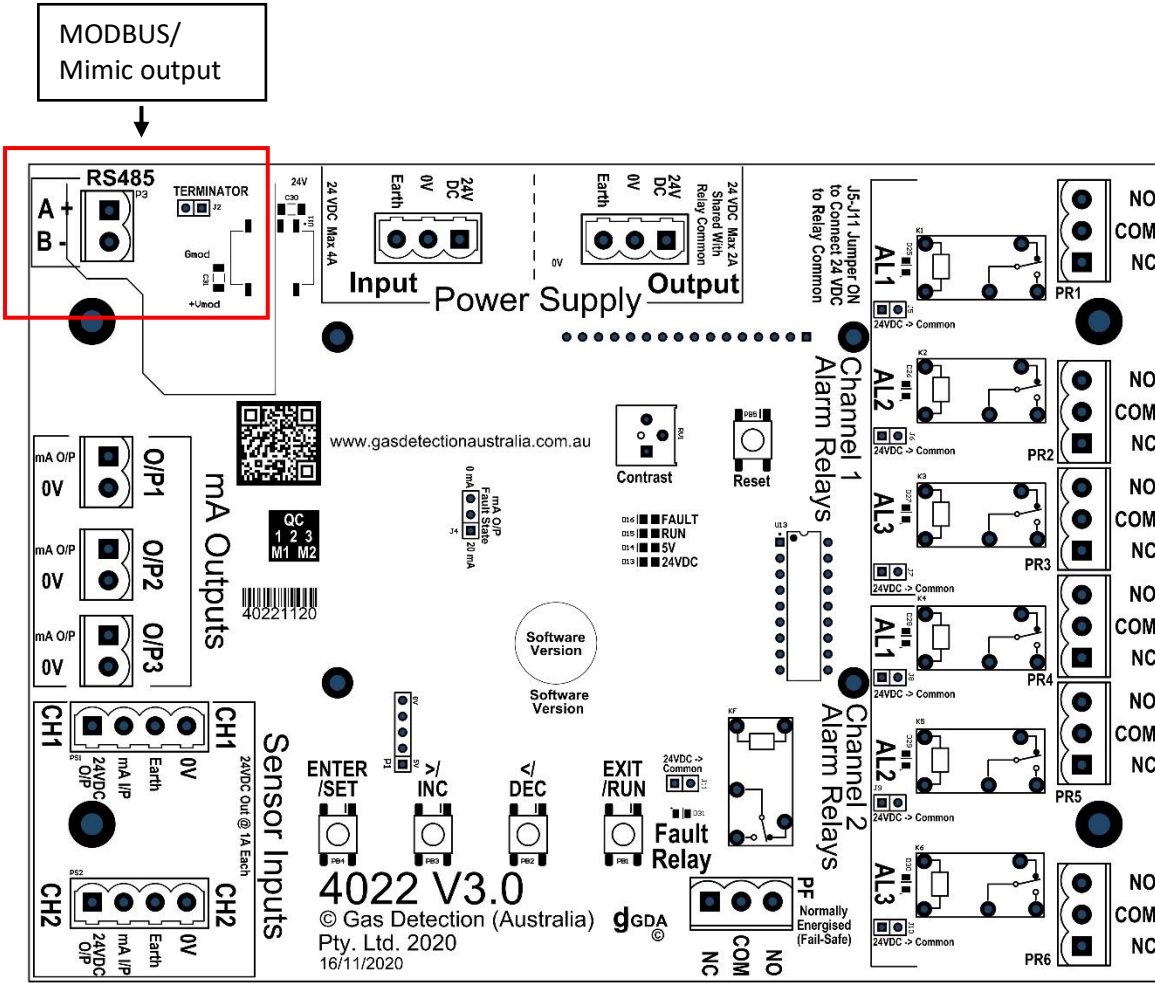

Figure 19: The above example of wiring the 4022 alarm relays using the Jumper J5-J11 to power the commons of the relays.

6 MODBUS



6.1 Protocol

Modbus RTU protocol (Not Modbus ASCII) via RS 485

9600 baud, 8 data, no parity, 1 stop bit.

Note: Modbus RTU requires 3.5 Character spaces between packets.
GDA advises that there should be at least 4ms between requests.

6.2 Single Registers

MODBUS Function Code	Address (dec)	Offset (dec)	Comment
0x04 (Input Registers)	00000	00001	CHAN 1 Concentration: 16 Bit Integer If Gas Range Is % LEL or % Vol. The Reading Value Is x 10
	00001	00002	CHAN 2 Concentration: 16 Bit Integer If Gas Range Is % LEL or % Vol. The Reading Value Is x 10
0x03 (Holding Registers)	00100	00101	CHAN 1 Gas Type CHAN 1: 16 Bit Integer (See Table Section 6.4)
	00101	00102	CHAN 2 Gas Type CHAN 2: 16 Bit Integer (See Table Section 6.4)
	00200	00201	CHAN 1 Units of Concentration: 16 Bit Integer Response: 0000 = PPM 0001 = % Vol. 0002 = % LEL
	00201	00202	CHAN 2 Units of Concentration: 16 Bit Integer Response: 0000 = PPM 0001 = % Vol. 0002 = % LEL
	00300	00301	CHAN 1 ON/OFF Status CHAN 1: 16 Bit Integer Response: 0000 = Off 0001 = On
	00301	00302	CHAN 2 ON/OFF status CHAN 2: 16 Bit Integer Response: 0000 = Off 0001 = On
	00400	00401	System Equipment ID: 16 Bit Integer Response: 4020
0x01 (Coil Status)	00100	00101	CHAN 1 Alarm 1: Single Bit If Bit Value is 0 = Alarm is Off If Bit Value is 1 = Alarm is On
	00101	00102	CHAN 2 Alarm1: Single Bit If Bit Value is 0 = Alarm is Off If Bit Value is 1 = Alarm is On
	00200	00201	CHAN 1 Alarm 2: Single Bit If Bit Value is 0 = Alarm is Off If Bit Value is 1 = Alarm is On
	00201	00202	CHAN 2 Alarm 2: Single Bit If Bit Value is 0 = Alarm is Off If Bit Value is 1 = Alarm is On
	00300	00301	CHAN 1 Alarm 3: Single Bit If Bit Value is 0 = Alarm is Off If Bit Value is 1 = Alarm is On
	00301	00302	CHAN 2 Alarm 3: Single Bit If Bit Value is 0 = Alarm is Off If Bit Value is 1 = Alarm is On
	00400	00401	System Fault: Single Bit If Bit Value is 0 = Alarm is Off If Bit Value is 1 = Alarm is On

6.3 Multiple Registers

Note: When reading multiple alarm levels (MODBUS Function Code = 01, **LENGTH = 2**, **OFFSET = 00#01**)

MODBUS Function Code	Offset	Comment
0x01 (Coil Status)	00101	ALARM 1: Double Bit CHAN 1: BIT 0 CHAN 2: BIT 1 If Bit Value is 0 = Alarm is Off If Bit Value is 1 = Alarm is On
	00201	ALARM 2: Double Bit CHAN 1: BIT 0 CHAN 2: BIT 1 If Bit Value is 0 = Alarm is Off If Bit Value is 1 = Alarm is On
	00301	ALARM 3: Double Bit CHAN 1: BIT 0 CHAN 2: BIT 1 If Bit Value is 0 = Alarm is Off If Bit Value is 1 = Alarm is On

6.4 Gas Type

16 Bit Integer	Gas Type	16 Bit Integer	Gas Type
0	CO	10	NH3
1	O2	11	NO2
2	CO2	12	Gas
3	FLM	13	R22
4	H2	14	R123
5	CH4	15	R134a
6	LNG	16	R407c
7	Prop	17	R410a
8	LPG	18	Refrg
9	H2S	19	" " (<i>Blank</i>)

Electrical Requirements:

Termination Resistors are required at both ends of the Bus (i.e., the furthest devices from the centre). These should match the impedance of the cable used. For Shielded Twisted Pair, this is typically 120Ω.

Ring or Star Topographies are NOT recommended for RS 485 Communications.

The MODBS may need to be Enabled See Section 4 for instruction of how to enter the menu system and follow the below steps to enable the MODBUS via RS 485.

To enable the MODBUS via RS 485.

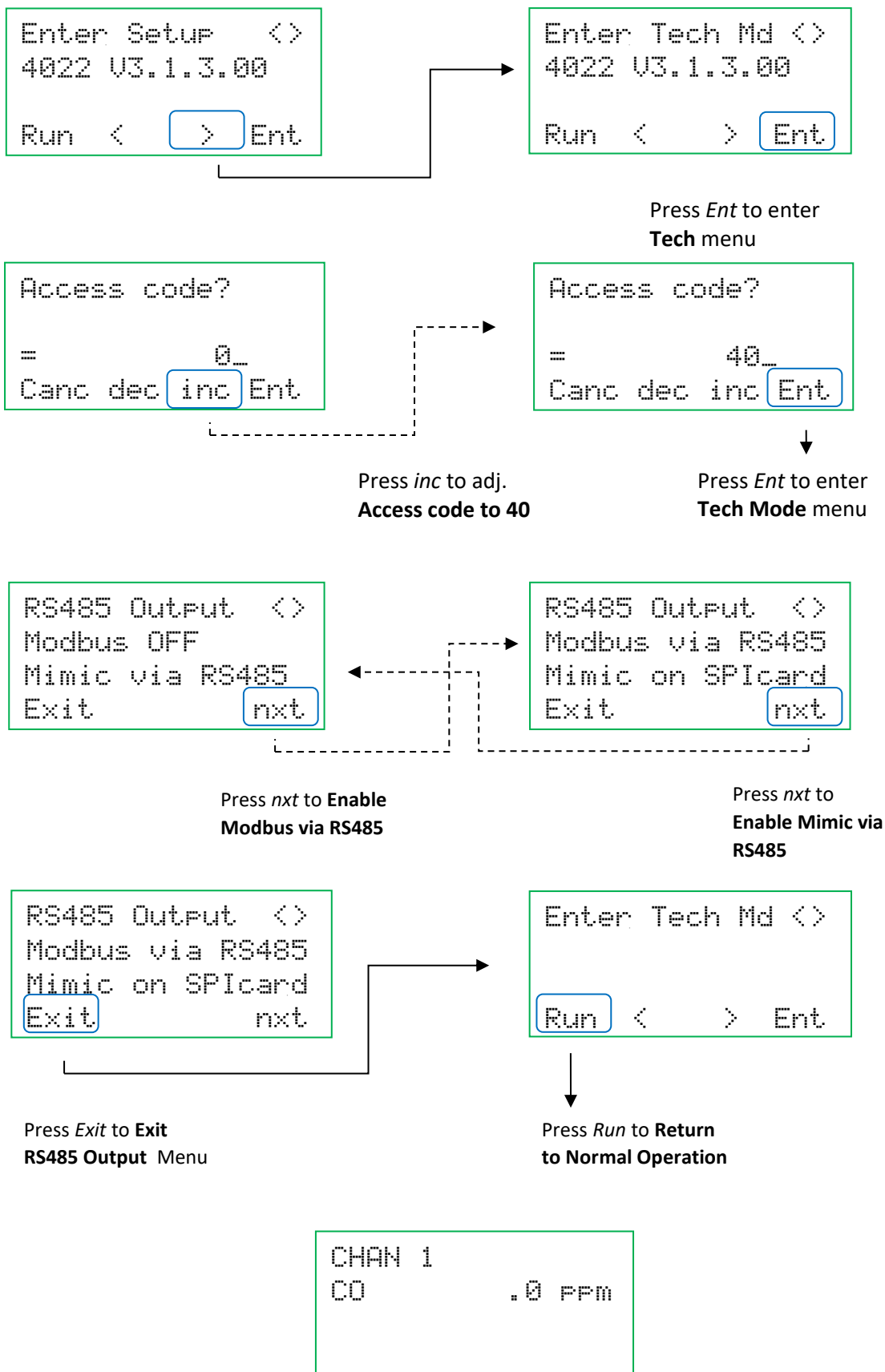

7 Manual Revision History

Version	Contents	Date
1.0	Initial revision of the Manual HW: V3.0 SW 2.13	11 March, 2021
1.1	Added MODBUS table and edited shield diagram	18 March, 2022

This product and operating manual are subject to change without prior notice for the improvement of product performance and ease of use.



Gas Detection (Australia) Pty Ltd

 07 4613 5111

 sales@gasdetect.com.au

 Unit K1, USQ, Baker Street

PO Box 597, Darling Heights, QLD 4350

 www.gasdetectionaustralia.com.au